

# **Cadmium, Chromium, Copper Lead, Nickel and Zinc in Sewage Sludges by Nitric Acid/AAS 1981**

**Methods for the Examination of Waters and Associated Materials**

# **Cadmium, Chromium, Copper, Lead, Nickel and Zinc in Sewage Sludges by Atomic Absorption Spectrophotometry following Digestion with Nitric Acid 1981**

## **Methods for the Examination of Waters and Associated Materials**

The method described for the determination of the above six metals in sewage sludges was designed for rapid analysis on a routine basis of typical sewage sludges. There may be atypical sludges or other circumstances which may necessitate the use of other methods to be published in this series.

### **Contents**

---

Warning to Users	2
About this Series	3
1 Performance Characteristics of the Method	4
2 Principle	5
3 Interferences	6
4 Hazards	6
5 Reagents	6
6 Apparatus	7
7 Sample Collection and Preservation	8
8 Determination of the Percentage Dry Solids and Preparation of the Dried Sludges	8
9 Analytical Procedure	9
10 Optimisation of Instrumental Conditions	11
11 Checking the Linearity of the Calibration Curves	11
12 Change of Concentration Range of the Method	11
13 Sources of Error	11
14 Checking the Accuracy of Analytical Results	12
15 References	12
Address for Correspondence	12
Membership responsible for this method	inside back cover

---

**London : Her Majesty's Stationery Office**

# Warning to users

The analytical procedures given in this booklet should only be carried out by competent trained persons, with adequate supervision when necessary. Local Safety Regulations must be observed. Laboratory procedures should be carried out only in properly equipped laboratories. Field operations should be conducted with due regard to possible local hazards, and portable safety equipment should be carried. Care should be taken against creating hazards. Lone working, whether in the laboratory or field, should be discouraged. Reagents of adequate purity must be used, along with properly maintained apparatus and equipment of correct specification. Specifications for reagents, apparatus and equipment are given in manufacturers' catalogues and various published standards. If contamination is suspected, reagent purity should be checked before use.

There are numerous handbooks on first aid and laboratory safety. Among such publications are: 'Code of Practice for Chemical Laboratories' and 'Hazards in the Chemical Laboratory' issued by the Royal Society of Chemistry, London; 'Safety in Biological Laboratories' (Editors Hartree and Booth), Biochemical Society Special Publication No. 5, The Biochemical Society, London, which includes biological hazards; and 'The Prevention of Laboratory Acquired Infection' Public Health Laboratory Service Monograph 6, HMSO, London.

Where the Committee have considered that a special unusual hazard exists, attention has been drawn to this in the text so that additional care might be taken beyond that which should be exercised at all times

when carrying out analytical procedures. It cannot be too strongly emphasised that prompt first aid, decontamination, or administration of the correct antidote can save life; but that incorrect treatment can make matters worse. It is suggested that both supervisors and operators be familiar with emergency procedures before starting even a slightly hazardous operation, and that doctors consulted after any accident involving chemical contamination, ingestion, or inhalation, be made familiar with the chemical nature of the injury, as some chemical injuries require specialist treatment not normally encountered by most doctors. Similar warning should be given if a biological or radio chemical injury is suspected. Some very unusual parasites, viruses and other micro-organisms are occasionally encountered in samples and when sampling in the field. In the latter case, all equipment including footwear should be disinfected by appropriate methods if contamination is suspected.

The best safeguard is a thorough consideration of hazards and the consequent safety precautions and remedies well in advance. Without intending to give a complete checklist, points that experience has shown are often forgotten include: laboratory tidiness, stray radiation leaks (including ultra violet), use of correct protective clothing and goggles, removal of toxic fumes and wastes, containment in the event of breakage, access to taps, escape routes, and the accessibility of the correct and properly maintained first-aid, fire fighting, and rescue equipment. If in doubt, it is safer to assume that the hazard may exist and take reasonable precautions, rather than to assume that no hazard exists until proved otherwise.

# About this series

This booklet is part of a series intended to provide recommended methods for the determination of water quality. In addition, the series contains short reviews of the more important analytical techniques of interest to the water and sewage industries. In the past, the Department of the Environment and its predecessors, in collaboration with various learned societies, has issued volumes of methods for the analysis of water and sewage culminating in 'Analysis of Raw, Potable and Waste Waters'. These volumes inevitably took some years to prepare, so that they were often partially out of date before they appeared in print. The present series will be published as individual methods, thus allowing for the replacement or addition of methods as quickly as possible without need of waiting for the next edition. The rate of publication will also be related to the urgency of requirement for that particular method, tentative methods being issued when necessary. The aim is to provide as complete and up to date a collection of methods and reviews as is practicable, which will, as far as possible, take into account the analytical facilities available in different parts of the Kingdom, and the quality criteria of interest to those responsible for the various aspects of the water cycle. Because both needs and equipment vary widely, where necessary, a selection of methods may be recommended for a single determinand. It will be the responsibility of the users – the senior analytical chemist, biologist, bacteriologist etc, to decide which of these methods to use for the determination in hand. Whilst attention of the user is drawn to any special known hazards which may occur with the use of any particular method, responsibility for proper supervision and the provision of safe working conditions must remain with the user.

The preparation of this series and its continuous revision is the responsibility of the Standing Committee of Analysts (to review Standard Methods of Quality Control of the Water Cycle). The Standing Committee of Analysts is one of the joint technical committees of the Department of the Environment and the National

Water Council. It has nine Working Groups, each responsible for one section or aspect of water cycle quality analysis. They are as follows:

- 1.0 General principles of sampling and accuracy of results
- 2.0 Instrumentation and on-line analysis\*
- 3.0 Empirical and physical methods
- 4.0 Metals and metalloids
- 5.0 General nonmetallic substances
- 6.0 Organic impurities
- 7.0 Biological methods
- 8.0 Sludge and other solids analysis\*
- 9.0 Radiochemical methods

The actual methods etc are produced by smaller panels of experts in the appropriate field, under the overall supervision of the appropriate working group and the main committee. The names of those associated with this method are listed inside the back cover.

Publication of new or revised methods will be notified to the technical press, whilst a list of Methods in Print is given in the current HMSO Sectional Publication List No 5, and the current status of publication and revision will be given in the biennial reports of the Standing Committee of Analysts.

Whilst an effort is made to prevent errors from occurring in the published text, a few errors have been found in booklets in this series. Correction notes for booklets in this series are given in the Reports of The Standing Committee of Analysts, published by the Department of the Environment but sold by the National Water Council, 1 Queen Anne's Gate, London SW1H 9TB. Should an error be found affecting the operation of a method, the true sense not being obvious, or an error in the printed text be discovered prior to sale, a separate correction note will be issued for inclusion in the booklet.

\*These two working groups are in process of being wound up. Their tasks are being redistributed among the other working groups.

T A DICK  
*Chairman*

L R PITTWELL  
*Secretary*

25 September, 1981

# Cadmium, Chromium, Copper, Lead, Nickel and Zinc in Sewage Sludges by Atomic Absorption Spectrophotometry following Digestion with Nitric Acid.

## 1981 Version

*Note:* Throughout this method cadmium, chromium, copper, lead, nickel and zinc are expressed as their respective elements Cd, Cr, Cu, Pb, Ni and Zn.

### 1 Performance Characteristics of the Method

(For further information on the determination and definition of performance characteristics see General Principles of Sampling and Accuracy of Results 1980, also published in this series)

1.1	Substances determined	Cadmium, chromium, copper, lead, nickel and zinc.			
1.2	Type of sample	Sewage sludge (wet or dried at 105°C).			
1.3	Basis of method	Digestion with nitric acid in a 50-ml calibrated borosilicate boiling tube followed by measurement of the metal concentrations by atomic absorption spectrophotometry in an air-acetylene flame.			
1.4	Range of application (without dilution of digest)	Cadmium	1-2000 mg/kg dry weight		
		Chromium	3-5000 mg/kg .. ..		
		Copper	2-5000 mg/kg .. ..		
		Lead	4-7500 mg/kg .. ..		
		Nickel	3-5000 mg/kg .. ..		
		Zinc	1-2000 mg/kg .. ..		
1.5	Calibration curve	Linear over the concentration ranges given in Section 1.4.			
1.6	Total standard deviation (expressed as mg/kg dry weight)	Metal	Concentration of metal (mg/kg)	Total standard deviation (mg/kg)	Degrees of freedom
	Sludge 1 (dried sludge) (a)	Cadmium	24.5	0.36 - 1.02	(a)
		Chromium	904	7.38 - 132.20	
		Copper	1783	16.43 - 119.70	
		Lead	736	10.42 - 44.81	
		Nickel	74.2	1.59 - 3.71	
		Zinc	1841	16.43 - 192.50	
	Sludge 2 (dried sludge) (a)	Cadmium	9.2	0.21 - 1.01	(a)
		Chromium	69.8	0.91 - 7.44	
		Copper	741	13.60 - 42.92	
		Lead	591	10.62 - 31.72	
		Nickel	37.5	0.1 - 2.63	
		Zinc	994	9.14 - 31.30	
	Sludge 3 (wet sludge) (b)	Cadmium	68	2.15	7
		Chromium	1379	44.2	9
		Copper	1630	35.2	12
		Lead	2282	80.4	5
		Nickel	724	18.2	7
		Zinc	6815	223	5
	Sludge 4 (wet sludge) (b)	Cadmium	198	3.51	10
		Chromium	564	20.2	6
		Copper	567	21.3	8
		Lead	324	13.7	7
		Nickel	744	13.6	11
		Zinc	1860	35.1	12

1.7 Limit of detection (b)  
(expressed as mg/kg dry weight)

The limits of detection for sludge analysis are difficult to quantify for some metals as almost all sludges contain levels of copper, lead and zinc significantly (at least 50 times) above the estimated limits of detection of the technique. The following results were calculated from the within batch standard deviation of 11 replicate blank measurements assuming a 0.5g sample of dried sludge.

Metal	Limit of detection (mg/kg)	Degrees of freedom
Cadmium	1	10
Chromium	3	10
Copper	2	10
Lead	4	10
Nickel	3	10
Zinc	1	10

1.8 Sensitivity (b)

Metal	Concentration (mg/kg)	Absorbance
Cadmium	100	0.40
Chromium	200	0.15
Copper	500	0.50
Lead	500	0.25
Nickel	200	0.15
Zinc	100	0.40

1.9 Bias

Not known.

1.10 Interference

See Section 3

1.11 Time required for analysis (b) The times (h) required for 6 elements in 30 samples and the associated calibration standards are given below

	Time (h)	
	Wet Sludge	Dry Sludge
Sample preparation	1	3
Digestion	3	1.5
Settling (minimum)	2	2
Analytical measurement	4	4

The times for dry sludge assume starting with dried unsieved material.

- (a) These data were obtained from an inter-laboratory exercise <sup>(1)</sup> involving 9 laboratories; sludge 1 was a digested sludge from a city sewage works; sludge 2 was a raw sludge from a rural sewage works. The number of determinations carried out varied so that the minimum number of degrees of freedom was 4 and the maximum number was 9.
- (b) These data were obtained at the Malvern Regional Laboratory, Severn-Trent Water Authority<sup>(2)</sup>.

## 2 Principle

0.5g of dried sludge or 10ml of wet sludge is digested with 6ml of nitric acid ( $d_{20}$  1.42) in a 50-ml calibrated borosilicate glass boiling tube. After the digestion is completed the contents of the tube are diluted with water to 50 ml, shaken, allowed to settle for two hours (or overnight) and the metals determined by atomic absorption spectrophotometry using an air-acetylene flame.

### 3 Interferences

3.1 Interelement effects in complex matrices such as sludge digests are dependent on the instrument and flame conditions used. Tests carried out to compare the results obtained for two sludges by nine laboratories using different instruments indicated satisfactory relative standard deviations for cadmium, copper, lead, nickel and zinc; the results for chromium were not satisfactory. Further tests were carried out by adding 2000 and 5000 mg/l lanthanum to some sludge digests, standards and blanks and comparing the results obtained with those obtained when no lanthanum was present. The results for cadmium, copper, lead, nickel and zinc were in good agreement with less than  $\pm 5\%$  difference; the results for chromium were not satisfactory. Also carrying out analysis of digests for copper, lead and zinc using both air-acetylene and nitrous oxide/acetylene flames indicated negligible interference effects.

3.2 There are very significant interelement effects for chromium determinations in the luminous air-acetylene flame. The degree of interference is very dependent upon the instrumental flame conditions and it can be minimized typically to  $\pm 20\%$  by using an acetylene rich non-luminous flame. These effects can be further minimized by the use of the nitrous oxide/acetylene flame and if this flame is used the digests, standards and blanks should contain 1000 mg/l potassium to suppress ionization.

### 4 Hazards

Digestions with nitric acid are potentially hazardous. The calibrated tubes should be positioned on the Kjeldahl multi-burner unit in a well ventilated fume cupboard, pointing away from the operator. It is essential to add anti-bumping granules to the blank to prevent bumping. The exhaust fumes from the atomic absorption spectrophotometer are toxic and must be ducted away.

### 5 Reagents

Analytical grade reagents are suitable unless otherwise specified. All reagents and standard solutions should be stored in polyethylene bottles unless otherwise specified.

#### 5.1 Water

The water used for the blank determinations and for preparing the reagents and standard solutions should have metal contents that are negligible compared with the smallest concentrations of the metals to be determined in samples. Water distilled from an all glass apparatus or deionized water is suitable.

#### 5.2 Nitric acid ( $d_{20}$ 1.42) (low in chromium)

##### 5.2.1 25% V/V nitric acid

Dilute  $25 \pm 1$  ml of nitric acid ( $d_{20}$  1.42) with water to 100 ml in a measuring cylinder.

##### 5.2.2 10% V/V Nitric acid

Dilute  $10 \pm 1$  ml of nitric acid ( $d_{20}$  1.42) with water to 100 ml in a measuring cylinder.

#### 5.3 Aluminium oxide anti-bumping granules

These should be soaked in 10% V/V nitric acid overnight, washed thoroughly in water, dried and stored in a dry bottle.

#### 5.4 Acid-washed kerosine

Shake approximately 100 ml of kerosine with  $25 \pm 1$  ml of 25% V/V nitric acid in a separating funnel. Allow to separate and discard the nitric acid layer. Place 10 ml of the acid washed kerosine in a small dropping bottle. Kerosine must be stored away from naked flames.

#### 5.5 Standard metal solutions

Prepare separate 1000 mg/l standard solutions for each metal by dissolving  $1.00 \pm 0.01$ g of the metal (purity greater than 99.9%) in  $100 \pm 1$  ml of nitric acid ( $d_{20}$  1.42) contained in a beaker. Transfer quantitatively to a 1-litre calibrated flask and dilute with water to the mark. Mix well. Alternatively, commercially available standards may be used.

## 6 Apparatus

### 6.1 An atomic absorption spectrophotometer

Equipped for an air-acetylene flame and with suitable hollow cathode lamps. A nitrous oxide/acetylene flame may be required for chromium. Background correction will be required for cadmium, nickel and lead. A general guide to the use of atomic absorption spectrophotometry is given in reference (3).

### 6.2 10-ml capacity calibrated glass/PTFE Winchester dispenser

Suitable for dispensing nitric acid. The dispenser should be set to  $6.0 \pm 0.1$  ml.

### 6.3 50-ml calibrated borosilicate glass tubes

Of internal diameter approximately 23 mm and fitted with ground glass stoppers.

### 6.4 10-ml calibrated glass tube

Of internal diameter approximately 14 mm as shown in figure 1. Cut off the tube at the 10 ml mark and flame end of the tube.

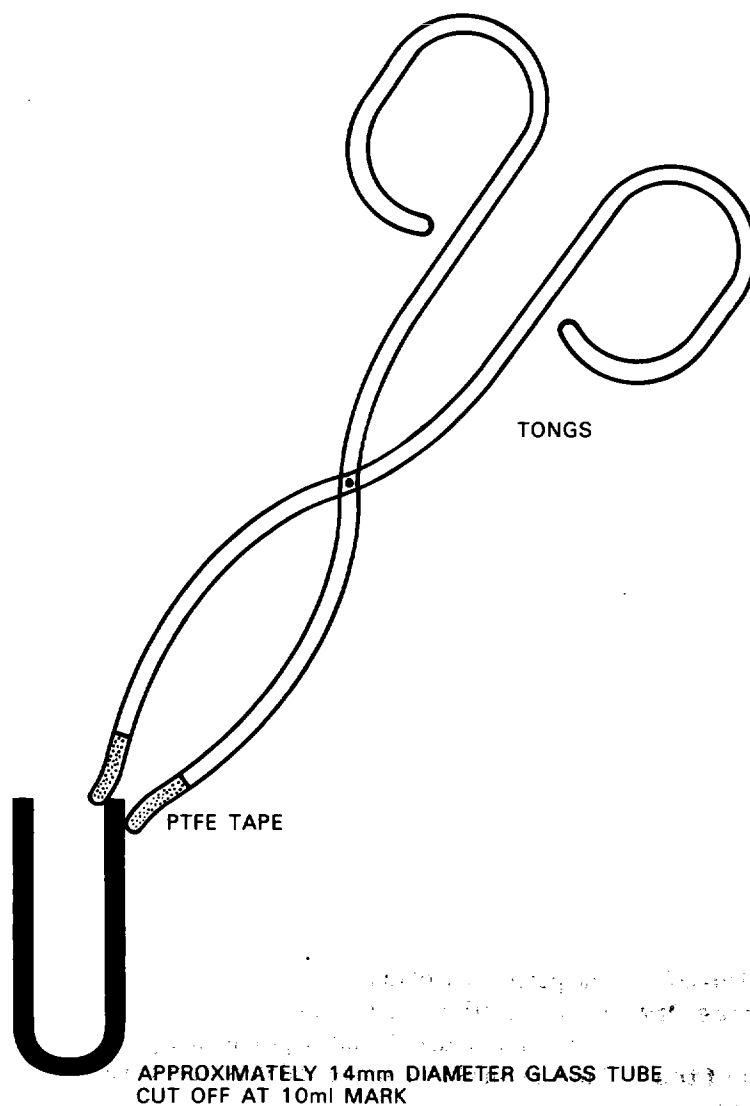
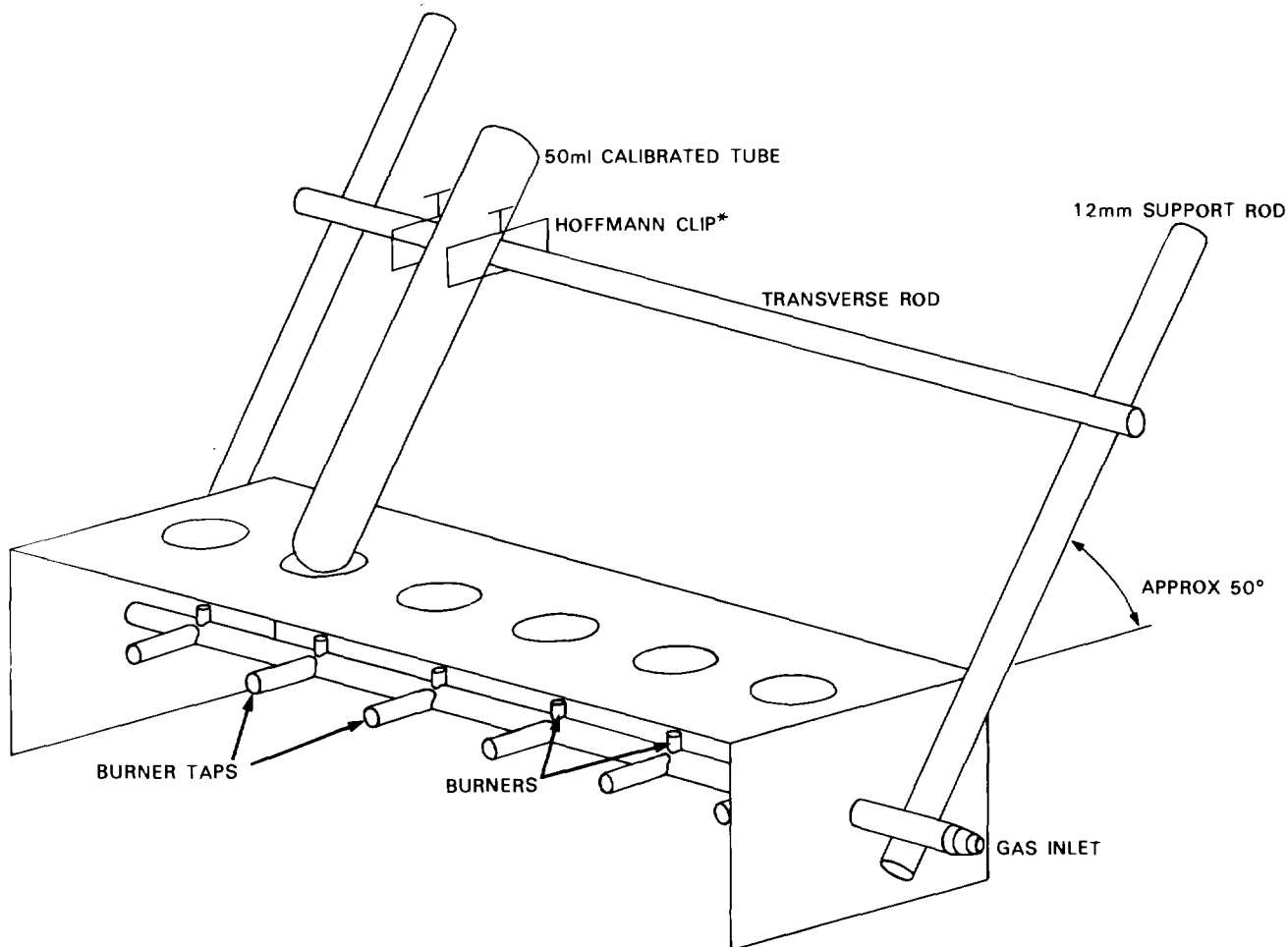

FIGURE 1 SAMPLING TUBE FOR WET SLUDGES

### 6.5 Kjeldahl gas multi-burner apparatus

As shown in figure 2. Alternatively the digestion can be carried out in an electrically heated aluminium block drilled with suitable holes to accept the 50-ml calibrated tubes.





\* THE TUBES ARE HELD BY THE HOFFMANN CLIPS AND CAN ONLY BE REMOVED VERTICALLY

FIGURE 2 KJELDAHL MULTI-BURNER APPARATUS FOR DIGESTIONS

**7 Sample Collection and Preservation**

No special sample collection or preservation techniques are normally required. A clean 2-litre plastic container with a wide mouth is suitable. The main problem is to obtain a representative sample (see another publication in this series <sup>(4)</sup>). In order to minimize bacterial activity the samples should be stored at approximately 4°C with the tops of the container slightly loosened to facilitate the escape of any gas which may form.

**8 Determination of the Percentage Dry Solids and Preparation of the Dried Sludges**

The percentage of dry solids in a wet sludge should be determined by drying a suitable aliquot at  $105 \pm 2^\circ\text{C}$  to constant weight. If the analysis is to be performed on the dried sludge, the sludge should be ground in a glass pestle and mortar and passed through a 2-mm mesh aluminium or stainless steel sieve.

## 9 Analytical Procedure

### READ SECTION 4 ON HAZARDS BEFORE STARTING THIS PROCEDURE

Step	Experimental Procedure	Notes
	<i>Dried Sludges</i>	
9.1	Transfer of $0.500 \pm 0.002$ g of the powdered sludge into a 50-ml calibrated borosilicate tube. Run $1.0 \pm 0.1$ ml of water down the side of the tube to wet the sample. Add 3 or 4 aluminium oxide anti-bumping granules.	
9.2	Carefully run $6.0 \pm 0.1$ ml of nitric acid ( $d_{20}$ 1.42) down the side of the tube. Place the tube in a rack and allow any vigorous initial reaction to subside. (If excessive foaming occurs, see note a.). Place the tube on the Kjeldahl multi-burner unit and light and adjust the flame until the sample gently refluxes (note b)	(a) The addition of 2 drops of the acid-washed kerosine from the small dropping bottle will minimize foaming. The burner must not be lit during this procedure. (b) An electric heating block can be used, but the rate of heating is then very dependent on the outer diameter of the glass tube.
9.3	Allow the sample to reflux for $15 \pm 3$ min. Allow the tube to cool for about 10 minutes and dilute with water to 50 ml. Replace the ground glass stopper, shake vigorously and allow to settle for at least two hours or preferably overnight (note c).	(c) If there is appreciable detritus floating on the surface, gently tap the base of the tube.
	<i>Wet Sludges</i>	
9.4	Vigorously shake all excess water from the 10-ml calibrated sampling tube (see Section 6.4). Then holding the tube in the PTFE tipped tongs (note d), quickly immerse the tube held at $45^\circ$ to the vertical and adjust to the vertical plane below the sludge surface. Remove from sludge and carefully wash the outside of the tube with water from a wash-bottle into a sink (note e).	(d) Wind plumbers' PTFE tape around the tips of conventional metal tongs (Figure 1). (e) For very viscous sludges it is sometimes easier to pour the well-shaken sludge into the tube which is held above a sink. This avoids air locks.
9.5	Carefully pour the sampling tube contents into the 50-ml calibrated glass tube and wash all remaining residues from the sampling tube into the 50-ml tube using a wash-bottle with a very fine jet (note f).	(f) 3–5 ml should be adequate for this washing out.
9.6	Add 3 or 4 aluminium oxide anti-bumping granules. Carefully run $6.0 \pm 0.1$ ml of nitric acid ( $d_{20}$ 1.42) down the side of the tube. Place the tube on a Kjeldahl multi-burner unit and adjust the flame until the sample boils at a fairly vigorous rate (note b.)	
9.7	Allow the sample to boil until the final volume is $7 \pm 1$ ml. Allow the tube to cool for about 10 minutes and dilute with water to 50 ml. Replace the ground glass stopper, shake vigorously and allow to settle for at least two hours or preferably overnight (note c).	
	<i>Blank Determination</i>	
9.8	<i>Dried Sludges</i> Two blanks should be run with each batch of determinations. Add $1.0 \pm 0.1$ ml of water and $6.0 \pm 0.1$ ml of nitric acid ( $d_{20}$ 1.42) to a 50-ml calibrated borosilicate tube. Add 3 or 4 aluminium oxide anti-bumping granules (note g). Reflux gently on the Kjeldahl multi-burner unit for $15 \pm 3$ min. Allow to cool and dilute with water to 50 ml.	(g) It is absolutely essential to add anti-bumping granules to the blank.

9.9 *Wet Sludges*

Two blanks should be run with each batch of determinations. Add  $10.0 \pm 0.5$  ml of water and  $6.0 \pm 0.1$  ml of nitric acid ( $d_{20} 1.42$ ) to a 50-ml calibrated borosilicated tube. Add 3 or 4 aluminium oxide anti-bumping granules (note g). Boil on the Kjeldahl multi-burner unit until the final volume is  $7 \pm 1$  ml. Allow to cool and dilute with water to 50 ml.

## Calibration Standards

9.10 Calibration standards of suitable concentration should be prepared by diluting with 10% V/V nitric acid appropriate aliquots of the standard metal solutions described in Section 5.5. Suitable standards contain 0.5, 1, 2, 5, 10, 15, 25, 35 and 50 mg/l (note h). Multi-element standards are stable; standards containing 2 mg/l or less should be prepared weekly; standards greater than 2 mg/l are stable for at least one month.

(h) The chromium should be present as chromium III.

## 9.11 Analytical Range

Element	Burner in Line mg/l	Burner Rotated mg/l (note i)
Cadmium	0 – 2	1 – 20
Chromium	0 – 10	5 – 50
Copper	0 – 10	5 – 50
Nickel	0 – 10	5 – 50
Lead	0 – 15	7 – 75
Zinc	0 – 2	1 – 20

(i) It is better to rotate the burner rather than use a less sensitive resonance line. The precision should be adequate for this type of analysis.

## 9.12 Background Correction

Background correction is essential when determining cadmium, nickel and lead (See section 6.1)

## Atomic absorption stage:

*Optimisation of instrumental conditions*

9.13 Set up the atomic absorption spectrophotometer as detailed in the manufacturer's handbook (note j). However, when determining chromium set the acetylene flow to produce a flame on the verge of luminosity. This does not give maximum sensitivity, but does minimize inter-element effects (note k).

(j) A wash solution of 1% V/V nitric acid should be aspirated after each aspiration of a calibration standard, blank or sample. Always wash out with distilled water the burner and spray chamber at the end of the run.

(k) A nitrous oxide/acetylene flame can be used to overcome interference effects (see Section 3.2)

9.14 *Wavelengths Used*

Cadmium	228.8 nm
Chromium	357.9 nm
Copper	324.7 nm
Lead	217.0 nm
Nickel	232.0 nm
Zinc	213.9 nm

Step	Experimental Procedure	Notes
	<i>Method of Measurement</i>	
9.15	Insert the nebuliser capillary into the tube. Care must be taken to avoid contact with the residue in the bottom of the tube (note l). Record the results, corrected for background if necessary (see step 9.12), as a concentration for each metal in each sample digest, blank and standard (by reference to the calibration curve)	(l) It has generally been found unnecessary to filter samples. However, if persistent nebuliser blockage occurs, the samples should be filtered using a suitable acid washed filter paper.
	Calculation of Results	
	<i>Solid Samples</i>	
9.16	The sample contains 100 (W-B) mg/kg dry weight where W is the concentration of metal in the digest and B is the concentration of metal in the blank (note m)	(m) Significant blanks should rarely be observed under normal operating conditions.
	<i>Liquid Samples</i>	
9.17	The sample contains $\frac{5000 \times (W-B)}{Y \times Z}$ mg/kg dry weight Where W is the concentration of metal in the digest B is the concentration of metal in the blank (note m) Y is the sample volume (ml) Z is % dry solids in the sample	

**10 Optimisation of Instrumental Conditions** Care must be taken when setting up the atomic absorption spectrophotometer otherwise adequate precision and accuracy will not be obtained. The burner head and spray chamber should be washed with hot water at the end of each run.

**11 Checking the Linearity of the Calibration Curves** The linearity of the calibration curves should be checked by running at least five calibration standards for each metal on at least two independent occasions before applying this method to any samples (see step 9.8). The calibration curve is normally linear for the range given in Section 1.4. If the calibration curve departs from linearity the range given in Section 1.4 should extend only to the highest concentration on the linear part of the curve. However with many modern atomic absorption spectrophotometers curve correction facilities may be used to give a direct concentration read out.

**12 Change of Concentration Range of the Method** If the metal concentrations in the sample digest (step 9.3 or 9.7) exceed the highest standard of the appropriate calibration curve then the measurement should be made on a suitable aliquot  $V_1$  ml, diluted with 10% V/V nitric acid to 50 ml. The dilution factor must be taken into account in the calculation of the result (steps 9.16 and 9.17) by multiplying by  $\frac{50}{V_1}$

**13 Sources of Error** The attention which it is necessary to pay sources of error depends on the accuracy required of the analytical results. The following sub-sections summarize the main sources of error.

### 13.1 Contamination

It is desirable to carry out the analysis in a laboratory in which no appreciable amounts of these metals or their compounds are handled. The technique and working conditions should be critically examined and any sources of contamination eliminated

or minimized. In particular, it is desirable to reserve the 10-ml and 50-ml glass tubes solely for this method.

### 13.2 Interfering substances

See Section 3. Chromium is the only element likely to be subject to significant interference effects and these are typically  $\pm 20\%$  for the majority of sludges when a non-luminous air/acetylene flame is used. The relative error appears greatest at low chromium concentrations (less than 100 mg/kg). These effects can be further minimized by using a nitrous oxide/acetylene flame and incorporating 1000 mg/l potassium (added as the nitrate) into suitable aliquots of the samples, standards and blanks. The effect of possible interfering substances may be determined by analysing water and sludge digests spiked with the metals concerned and various concentrations of the potential interfering substance.

## 14 Checking the Accuracy of Analytical Results

Once methods have been put into normal routine operation, many factors may subsequently, adversely affect the accuracy of the analytical results. It is recommended that experimental tests, to check certain sources of inaccuracy, should be made regularly. Many types of tests are possible <sup>(5)</sup> and they should be used as appropriate. As a minimum, however, it is suggested that 10 ml of a suitable standard solution of the metals in 10% V/V nitric acid should be digested, together with, and in exactly the same manner as, the samples (see steps 9.6 and 9.7). The results obtained should be plotted on a quality control chart, which will facilitate detection of inadequate accuracy and also allow the standard deviation of routine analytical results to be determined.

## 15 References

- (1) Thompson KC and Wagstaff K, *Analyst*, 1980, **105**, 883
- (2) Department of the Environment, File WS/646/59/HNO<sub>3</sub>/4
- (3) Standing Committee on Analysts, *Atomic Absorption Spectrophotometry – an Essay Review*, HMSO, London, 1980.
- (4) Standing Committee on Analysts, *The Sampling and Initial preparation of Sewage and Water Works Sludges, Soils, Sediments and Plant Materials prior to Analysis*. HMSO, London, 1977.
- (5) Wilson AL and Cheesemen RV, Water Research Centre, *Technical Report TR 66*, 1978.

## Address for Correspondence

However thoroughly a method may be tested, there is always the possibility of a user discovering a hitherto unknown problem. Users with information on this booklet are requested to write to:

The Secretary  
The Standing Committee of Analysts  
The Department of the Environment  
43 Marsham Street  
LONDON, SW1P 3PY  
England.

# Department of the Environment/National Water Council

## Standing Committee of Analysts

### Members of the Committee Responsible for this Method:

Mr P J Ballinger <sup>3,4</sup>		Mr P J Long <sup>1</sup>	
Dr G I Barrow <sup>1</sup>		Mr G F Lowden <sup>2*</sup>	to 1980
Dr M L Berrow <sup>2,3,4</sup>		Dr P J Matthews <sup>3</sup>	
Dr G A Best <sup>1</sup>	from 1980	Mr J C McCullins <sup>1</sup>	
Mr W Carr <sup>2</sup>		Mr P Morries <sup>1</sup>	
Dr J M Carter <sup>1</sup>		Mr D Myles <sup>1</sup>	
Mr E I Clark <sup>3</sup>		Dr E J Newman <sup>2</sup>	
Dr G W Clayfield <sup>1</sup>		Mr A H Nield <sup>1</sup>	
Mr B E P Clement <sup>1</sup>		Dr D I Packham <sup>1</sup>	from 1980
Mr E C Conchie <sup>2</sup>		Dr H A Painter <sup>1,3</sup>	
Dr R L Cooper <sup>1</sup>		Dr R Perry <sup>3</sup>	
Dr B T Croll <sup>1</sup>		Mr J F Palframan <sup>2</sup>	
Mr T A Dick <sup>1</sup>		Dr J E Portmann <sup>1,3</sup>	
Mr J W R Dutton <sup>1,2</sup>		Mr L D Purdie <sup>1</sup>	
Dr W H Evans <sup>3</sup>		Mr B D Ravenscroft <sup>1</sup>	
Mr B J Farey <sup>2</sup>		Mr D L Redhead <sup>4</sup>	
Mr M G Firth <sup>2</sup>	to 1980	Mr B Rhodes <sup>1</sup>	
Dr J Gardiner <sup>1,2*</sup>	from 1980	Prof J P Riley <sup>1,2</sup>	
Mr G I Goodfellow <sup>1</sup>	from 1980	Mr A H Ross <sup>4</sup>	
Mr K Goodhead <sup>1</sup>	to 1980	Mr I R Scholes <sup>2</sup>	
Mr T R Graham <sup>1</sup>		Mr A Tetlow <sup>1</sup>	from 1980
Mr I Harper <sup>1</sup>		Dr K C Thompson <sup>2</sup>	
Mr E Hodges <sup>1,3</sup>		Dr G Topping <sup>2</sup>	
Mr G J Holland <sup>1</sup>		Dr A M Ure <sup>1</sup>	from 1980
Dr D T E Hunt <sup>1,2</sup>		Mr J L Vosser <sup>3,4*</sup>	to 1980
Mr O D Hydes <sup>2,4*</sup>		Mr B T Witham <sup>1</sup>	
Mr R H Jenkins <sup>2</sup>	from 1980	Mr A L Wilson <sup>1</sup>	to 1980
Mr V H Lewin <sup>3</sup>		Mr A A Wood <sup>3</sup>	
Mr W M Lewis <sup>1,2</sup>	to 1980	Mr P Worthington <sup>3,4*</sup>	from 1980

<sup>1</sup> Members of the Standing Committee

<sup>2</sup> Members of Working Group 4.0

<sup>3</sup> Members of Working Group 8.0

<sup>4</sup> Members of the Panel

\* Occasional coopted members (modifies the preceding symbol)

**HER MAJESTY'S STATIONERY OFFICE**

*Government Bookshops*

49 High Holborn, London WC1V 6HB

13a Castle Street, Edinburgh EH2 3AR

41 The Hayes, Cardiff CF1 1JW

Brazennose Street, Manchester M60 8AS

Southey House, Wine Street, Bristol BS1 2BQ

258 Broad Street, Birmingham B1 2HE

80 Chichester Street, Belfast BT1 4JY

*Government publications are also available  
through booksellers*