

The Sampling of Oils, Fats, Waxes and Tars in Aqueous and Solid Systems 1983

Methods for the Examination of Waters and Associated Materials

The Sampling of Oils, Fats, Waxes and Tars in Aqueous and Solid Systems 1983

Methods for the Examination of Waters and Associated Materials

Contents

Warning to Users

About this Series

Introduction

1. Sampling of Oils, Fats, Waxes and Tars from Natural Systems
 - 1.1 Sampling the Water Column
 - 1.1.1 Sampling Surface Films
 - 1.1.2 Sampling Water Below the Surface
 - 1.1.3 Sampling Bottom Sediments
 - 1.2 Sampling of Beaches
 - 1.3 Sampling of Ground Waters
 - 1.4 Sampling of Soil and Rock
 - 1.5 Sampling of SewageFigures 3-10
2. Sampling of Oils, Fats, Waxes and Tars in Plant and Factory Systems
 - 2.1 Nature of the Sample and Sample Environment
 - 2.2 Time and Frequency of Sampling
 - 2.3 Sample Point Location
 - 2.4 Methods of Sampling
 - 2.5 Sampling Loops
 - 2.6 Automatic Sampling TechniquesFigures 11-13
3. Sample Handling
4. Reference
Table 1

Address for correspondence

Membership Responsible for this Booklet.

London Her Majesty's Stationery Office

Warning to Users

The analytical procedures given in this booklet should only be carried out by competent trained persons, with adequate supervision when necessary. Local Safety Regulations must be observed. Laboratory procedures should be carried out only in properly equipped laboratories. Field operations should be conducted with due regard to possible local hazards, and portable safety equipment should be carried. Care should be taken against creating hazards. Lone working, whether in the laboratory or field, should be discouraged. Reagents of adequate purity must be used, along with properly maintained apparatus and equipment of correct specifications. Specifications for reagents, apparatus and equipment are given in manufacturers' catalogues and various published standards. If contamination is suspected, reagent purity should be checked before use.

There are numerous handbooks on first aid and laboratory safety. Among such publications are: 'Code of Practice for Chemical Laboratories' and 'Hazards in the Chemical Laboratory' issued by the Royal Society of Chemistry, London; 'Safety in Biological Laboratories' (Editors Hartree and Booth), Biochemical Society Special Publication No 5, The Biochemical Society, London, which includes biological hazards; and 'The Prevention of Laboratory Acquired Infection', 'Public Health Laboratory Service Monograph 6, HMSO, London.

Where the Committee have considered that a special unusual hazard exists, attention has been drawn to this in the text so that additional care might be taken beyond that which should be exercised at all times when carrying out analytical procedures. It cannot be too strongly

emphasised that prompt first aid, decontamination, or administration of the correct antidote can save life; but that incorrect treatment can make matters worse. It is suggested that both supervisors and operators be familiar with emergency procedures before starting even a slightly hazardous operation, and that doctors consulted after any accident involving chemical contamination, ingestion, or inhalation, be made familiar with the chemical nature of the injury, as some chemical injuries require specialist treatment not normally encountered by most doctors. Some very unusual parasites, viruses and other micro-organisms are occasionally encountered in samples and when sampling in the field. In the latter case, all equipment including footwear should be disinfected by appropriate methods if contamination is suspected.

The best safeguard is a thorough consideration of hazards and the consequent safety precautions and remedies well in advance. Without intending to give a complete checklist, points that experience has shown are often forgotten include: laboratory tidiness, stray radiation leaks (including ultra violet), use of correct protective clothing and goggles, removal of toxic fumes and wastes, containment in the event of breakage, access to taps, escape routes, and the accessibility of the correct and properly maintained first-aid, fire fighting, and rescue equipment. Hazardous reagents and solutions should always be stored in plain sight and below face level. Attention should also be given to potential vapour and fire risks. If in doubt, it is safer to assume that the hazard may exist and take reasonable precautions, rather than to assume that no hazard exists until proved otherwise.

About this Series

This booklet is part of a series intended to provide both recommended methods for the determination of water quality, and in addition, short reviews of the more important analytical techniques of interest to the water and sewage industries. In the past, the Department of the Environment and its predecessors, in collaboration with various learned societies, have issued volumes of methods for the analysis of water and sewage culminating in 'Analysis of Raw, Potable and Waste Waters'. These volumes inevitably took some years to prepare, so that they were often partially out of date before they appeared in print. The present series will be published as individual methods, thus allowing for the replacement or addition of methods as quickly as possible without need of waiting for the next edition. The rate of publication will also be related to the urgency of requirement for that particular method, tentative methods being issued when necessary. The aim is to provide as complete and up to date a collection of methods and reviews as is practicable, which will, as far as possible, take into account the analytical facilities available in different parts of the Kingdom, and the quality criteria of interest to those responsible for the various aspects of the water cycle. Because both needs and equipment vary widely, where necessary, a selection of methods may be recommended for a single determinand. It will be the responsibility of the users — the senior analytical chemist, biologist, bacteriologist etc, to decide which of these methods to use for the determination in hand. Whilst the attention of the user is drawn to any special known hazards which may occur with the use of any particular method, responsibility for proper supervision and the provision of safe working conditions must remain with the user.

The preparation of this series and its continuous revision is the responsibility of the Standing Committee of

Analysts (to review Standard Methods for Quality Control of the Water Cycle). The Standing Committee of Analysts is a committee of the Department of the Environment set up in 1972. Currently it has seven Working Groups, each responsible for one section or aspect of water cycle quality analysis. They are as follows:—

- 1.0 General principles of sampling and accuracy of results
- 3.0 Empirical and physical methods
- 4.0 Metals and metalloids
- 5.0 General non-metallic substances
- 6.0 Organic impurities
- 7.0 Biological methods
- 9.0 Radiochemical methods.

The actual methods and reviews are produced by smaller panels of experts in the appropriate field, under the overall supervision of the appropriate working group and the main committee. The names of those associated with this method are listed inside the back cover. Publication of new or revised methods will be notified to the technical press, whilst a list of Methods in Print is given in the current HMSO Sectional Publications List No 5.

Whilst an effort is made to prevent errors from occurring in the published text, a few errors have been found in booklets in this series. Correction notes and minor additions to published booklets not warranting a new booklet in this series will be issued periodically as the need arises. Should an error be found affecting the operation of a method, the true sense not being obvious, or an error in the printed text be discovered prior to sale, a separate correction note will be issued for inclusion in that booklet.

L R PITTWELL
Secretary

31 October 1983

Sampling of Oils, Fats, Waxes and Tars in Aqueous and Solid Systems

Introduction

Sampling techniques must be selected with great care if the results of the measurements are to fulfil the intended purpose. Therefore, it is worthwhile expending appreciable time and effort on the planning and design stages of programmes. The important points of sampling have been discussed in "General Principles of Sampling and Accuracy of Results", Part 4, ⁽¹⁾, and the planning aspects of these are summarised in figures 1 and 2.

The aim of this document is to detail the best available means of sampling aqueous systems, including the boundary areas, for their oils, fats and, or, waxes content. Generally, there are three principal reasons for the measurements of these materials in water, namely:—

- (i) for identification of the sources of spillage
- (ii) to measure the quantity of a spillage
- (iii) to measure the concentration present in a water sample.

As the first two of these reasons often refer to the measurement of oils, fats, and waxes in natural water systems when measurement of the quantity is difficult and is often not required, and the third is usually of importance in plant and site operations, an arbitrary classification of sampling from "natural systems" and from "plant, or factory installations" has been made.

There are other companion booklets dealing with special aspects of sampling included in this series, which may also contain information of use when sampling for oils, fats, waxes and tars. These include:

- The Sampling and Initial Preparation of Sewage and Waterworks Sludge Soils, Sediments and Plant Materials prior to Analysis 1977 (together with the appropriate section in Additions, Corrections and Index to 1984);
- The Sampling of Rivers and Streams 1983;
- The Bacteriological Examination of Drinking Water Supplies 1982;
- Methods for the Isolation and Identification of Salmonellae from Water and Associated Materials 1982.

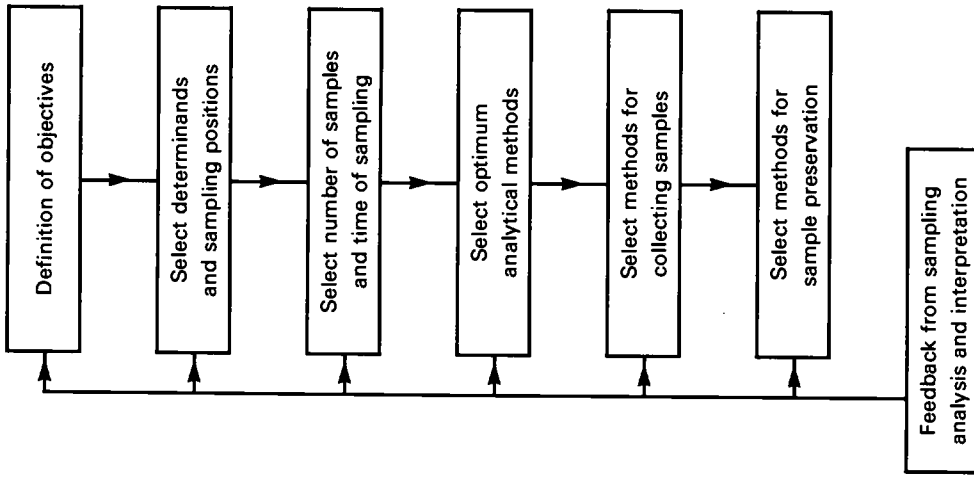

FIGURE 1
 SEQUENTIAL CONSIDERATION OF
 FACTORS INVOLVED IN THE DESIGN
 OF SAMPLING PROGRAMMES (Ref 1)

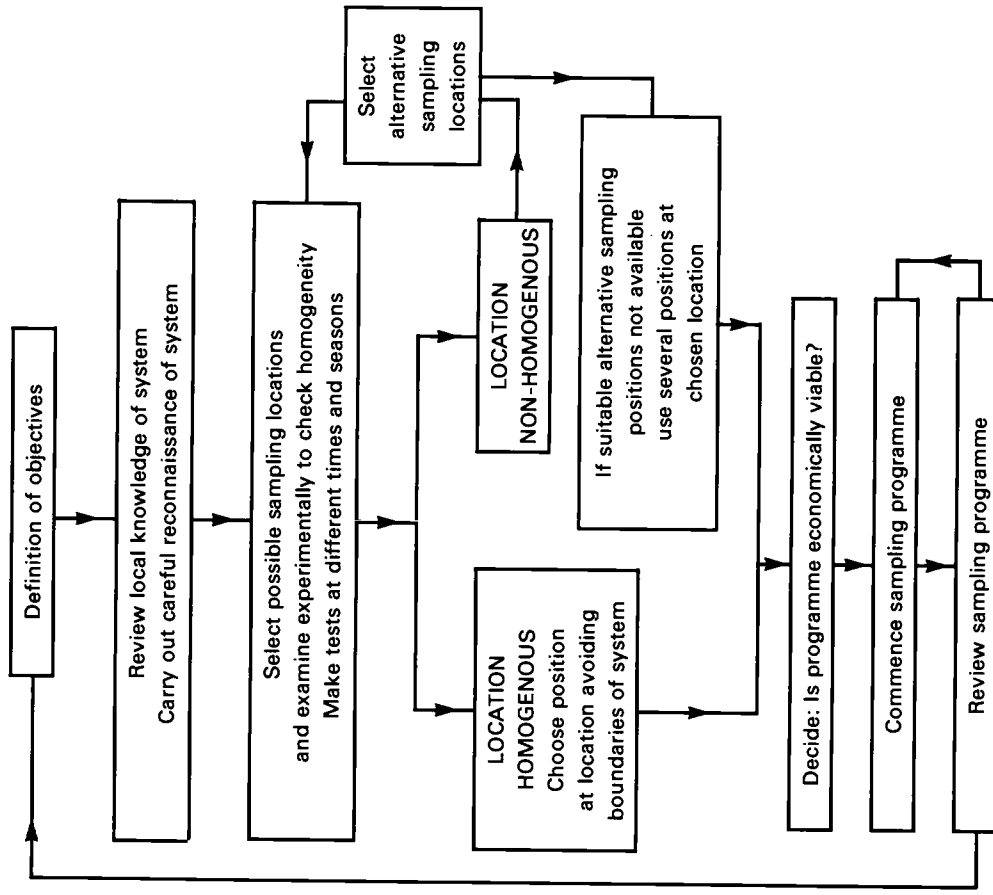

FIGURE 2
 SELECTION OF SAMPLING LOCATION AND POSITION (Ref 1)

1. Sampling of Oils, Fats, and Waxes from Natural Systems

In this section it is assumed that the total quantity of oil, fat or wax present is not being measured and a sample is required for identification purposes or as an assay of the concentration present from an oil spill. Only in the case of oil in a soil environment is a total measurement of the quantity considered. The Section is divided into the following areas of interest:—

- 1.1 The water column, including the surface and sediments
- 1.2 Beaches
- 1.3 Ground waters
- 1.4 Soils
- 1.5 Sewage

1.1 Sampling the Water Column

Oil spilled on the surface of the water undergoes rapid evaporative loss, and in turbulent areas may collect considerable quantities of suspended sediment. Both of these processes increase the specific gravity of the oil, and the residual material may eventually sink and become incorporated into sediments. Studies of the fate and effects of spilled hydrocarbons must include an examination of samples from the whole water column, from the surface film to the bottom sediments.

The solubility of oil in water is low, and a large proportion of the oil is likely to be present either as droplets or in association with particulate matter, implying an uneven distribution of oil. The low solubility leads to a further sampling problem, namely the tendency of hydrocarbons to adsorb onto the inner surfaces of sampling equipment. Samplers must therefore be constructed from materials such as glass, teflon or stainless steel which can be solvent rinsed before the sample is taken, and the sample bottle should be rinsed after the sample has been taken for analysis and the washings included in the analysis. If this is not done the apparent hydrocarbon concentration in the sample is reduced and the hydrocarbon remaining in the sampler may be desorbed into a future sample,^(2,3). The surface film is particularly rich in hydrophobic materials, including hydrocarbons, and to avoid contamination samplers used for collecting water below the surface should be lowered closed and only opened when at the required sampling depth.

Oil spreads rapidly on the water surface from a marine engine, and it is not usually possible to collect uncontaminated surface film samples from a large vessel. A small boat, for example a commercially available inflatable must be used. Water samples from less than 10 meters below the surface should be taken as soon as the ship comes to a halt, as in a short time the water may be contaminated. Reference samples of fuel oil, bilge water, lubricating oils and greases should be taken from ships used for sampling. These should be analysed by high-resolution gas chromatography and the hydrocarbon profiles compared with those of the sample to identify any contamination.

1.1.1 Sampling Surface Films

High concentrations of hydrocarbons may be found in the surface film of water as they, and other non-polar organic compounds collect in a layer which may be only one molecule thick. The surface film is a particularly interesting region of the water column as it is at the air-water interface that the processes of evaporation, dissolution and photodegradation occur. Whilst instruments to measure the thickness of the oil layer have been developed based on silicon photocells in a narrow strip form to monitor changes in light intensity they are only suitable at present for measuring layers greater than $2000\mu\text{m}$ thick,⁽⁴⁾. Surprisingly when this measurement is applied to wave water conditions the maximum thickness has been measured at the wave crests.

The Garret screen is the most commonly used sampler, and it consists of a net which is stretched over a frame all of which is constructed in stainless steel. The mesh is lowered into water by handles welded to the sides and the surface film clings to the mesh from which it can be removed by means of a solvent. The samples collected in this way are 150 to 450 μm thick,⁽⁵⁾. Russian workers have reported the use of a nylon mesh to obtain an oil sample said to be 220 μm thick,⁽⁶⁾.

Another sampler which has been frequently used is the Harvey rotating drum samplers, shown in figure 3,⁽⁷⁾. The drum is rotated by means of an electric motor and the oily film adhering to the drum is removed by means of a wiper blade. This collects a sample which is 60–100 μm thick, thinner than that which is collected when the Garret screen is used. A comparative study has shown higher values are obtained using the drum method of sampling as against the screen method,⁽⁸⁾.

Glass or plastic plates attached to various types of float have been used for shearing off layers of oil on surface water. One such device is the “Afrodita-1”,⁽⁹⁾. The collector consists of two foam plastic floats which are connected by stainless steel couplings for greater rigidity and stability. Fastened between the floats is a 3 mm thick perspex sheet containing funnel shaped cavities which are connected by vacuum hoses to a T joint which is connected to the container by a hose. Rudders which enable the device to be operated at a specified depth and so determine the thickness of the water layer in the range 0 to 20 cm are attached to the lower part of the collector. The thickness of the collected layer is dependent on the movement of the surface, wind velocity and the angle to the horizontal of the perspex sheet.

In two of the more recent methods the surface film is converted to a solid for removal and analysis of the oils, fats and waxes present. In the first, a probe is cooled to -196°C by using liquid nitrogen and is touched onto the water surface freezing a layer approximately 1000 μm thick in less than a second. In the second method a mixture of polyvinyl chloride in a solvent is sprayed on to the sea surface to form a flexible solid film after the solvent has evaporated which takes about two minutes⁽¹⁰⁾.

Often a less precise method is used in which a sample is taken using a hose discharging into an evacuated bottle, sometimes called a “slurp” bottle. In one pattern the collector is a glass tube in the centre of a foam plastic float measuring 20 cm on each side. The lower end of the glass tube is 3 cm below the water surface. The upper end is connected by a rubber hose to a glass bottle which can be evacuated⁽²⁾.

It should be noted that in assessing any results from measuring the thickness of the oil film the results will only be comparable with those obtained from a similar type of sampler.

A Neuston net having a 150 μm mesh size and a mouth opening of 80 by 30.5 cm and about 4 m in length mounted on a wooden ski or sled float has been used for collecting solid fragments of petroleum tar, (see figure 4),⁽¹¹⁾. Whilst this net has been used to collect oil it is not certain how quantitative it is,^(12,13). Models vary in the exact dimensions of the frame, keel and floats.

1.1.2 Sampling Water below the surface

All glass sampling bottles which can be opened at the desired depth are usually taken down to a depth of about 60 to 70 metres. Below this depth the bottles implode. A typical sample bottle arrangement is shown in figure 5.

Most of the commercial samplers available for sampling sea-water at depth, for example the Niskin, the Knudsen, the NIO bottle, etc. are not suitable for the collection of samples for hydrocarbon analysis as the plastic materials used in their construction absorb or desorb organic materials. However, because of the advantages of using a single sampler the Niskin bottles continue to be used despite the errors which can be introduced^(14,15). The Blumer sample consists of a glass liner inside an aluminium pressure housing which allows it to be used down to 4500 m⁽¹⁶⁾. The sample is taken at the required depth when a pre-set rupture disc breaks. A Teflon lined plastic sample bottle enables the bottle to be rinsed without the risk of contamination; this is used in the “Go-flo” unit manufactured by General Oceanics. The bottle opens automatically at 10 m and is closed at the sampling depth.

The rate of movement of oil from the surface of the sea to the sea-bed is sometimes required. For this purpose sediment traps are used in "strings" spaced at intervals between the surface and the seabed and are kept in place for several days. A large number of different designs of trap have been used, and the trapping efficiency varies with the size and shape,^(17, 18) but a typical suspension system and design of trap are shown in figures 6 and 7, respectively.

The mooring is constructed of synthetic fibre rope in a 'U' configuration (Fig. 6). A pick up rope and associated pallets lead to a sub-surface buoy which can be up to 30 m below the surface holding taut a rope to which the sedimentation traps are attached. The sub-surface buoy is anchored by means of a 150 kg clump of chain. A 5 kg anchor of the modified Danforth type prevents any lateral drag. A buoyant ground rope of 220 m runs from the anchor clump to a weight of 25 kg which anchors a further buoyant rope and a single surface marker. The trap is detailed in Fig. 7.

1.1.3 Sampling Bottom Sediments

The most recently deposited sediment is present as an unconsolidated flocculent layer at the surface of the sediment and a grab type of sampler often pushes away the lightest material from its path. However, bottom sediments are usually sampled by means of a grab, often fitted with buckets made of stainless steel to aid cleaning. Many different types of grabs have been used, and the choice depends on the substrate being sampled. Grabs in which the jaws meet at the bottom, for example, Day, or Smith-McIntyre when operated on a stoney surface allow some of the sample to be flushed out during the recovery period when the jaws are held apart by stones. Under these circumstances it is preferable to use a rotating bucket, for example the Shipek sampler shown in figure 8. Some grab samplers fail to operate in very soft sediments as there may not be sufficient impact energy to operate the trigger mechanism.

Grabs should be cleaned with solvent before use and deployed using a clean nylon or polypropylene rope to avoid contamination of the sample. If a steel cable is used, a 6 to 7m clean rope should be placed between the steel cable and the grab to prevent contamination from the lubricants used on the cable.

Core samples are used where the deposition of oil over a long time period is to be considered. However, coring devices are usually large and often difficult to use at sea, except in calm conditions.

1.2 Sampling on Beaches

On contaminated beaches the thickness of the oil layer, its type, and its physical state vary greatly. The oil can vary from light distillates, through sticky "chocolate mousse" emulsions, to tarballs and "moussecrete". "Moussecrete" is the name given to a mixture of weathered oil, sand and shingle which resembles the texture of concrete. Access to a contaminated beach does not usually present any problems and sampling is easier than at sea.

Experience has shown that beaches can be contaminated simultaneously with oil from more than one source and of different types. Careful inspection is necessary to ensure that the correct samples are taken.

Medical wooden tongue depressors which can be obtained from chemists' shops have proved ideal for handling oil samples from beaches. They can be used as disposable spatulas for scraping oil from rocks, groynes etc and for lifting oil from the surface of beaches with no fear of contamination. After collection, samples should be placed in clean glass containers and closed with a tight-fitting lid. In the case of oil adhering to seaweed or debris, the complete specimen should be placed in the bottle. Sample bottles with a wide mouth should be used. In no circumstances should samples of oil be heated or melted as this can interfere with identification.

Some refined petroleum products and fresh crude oils tend to sink into a sandy beach, particularly when oil dispersants have been used on the oil. In these cases, and any others where sediments are to be sampled, a solvent cleaned stainless steel spade is the best means of removing material without contamination. This method should also be used when removing beach material to uncover oil buried by tidal action or wind blown sand.

In cases where pollution of inshore waters is being caused by oil buried in beaches, it may be necessary to analyse the interstitial water flowing through the beach sediment. This may be sampled at low tide by digging a hole, using a solvent cleaned stainless steel spade, and allowing the hole to fill with water. A weighted bottle may then be used to obtain the water sample. Care must be taken to prevent sand from the side of the hole falling into the bottle which may cause contamination. This can sometimes be done using an inverted filter funnel over the neck of the bottle.

Birds and animals contaminated with oil are often difficult to handle as their size precludes the use of most glass containers. Plastic bags, on the other hand can cause contamination particularly if organic solvents are used to recover oil smears from the bag. Removal of the oil from the bird's feathers may also prove difficult and natural oils from the plumage may cause contamination. Use of large clean metal containers may be more suitable. Unfortunately, experience has shown that the decay organisms and enzymes in body fluids can substantially alter oils, fats and waxes especially once putrefaction has set in. Natural skin and body oils and fats from the bird or animal can also complicate the identification. Collection of rotting specimens for subsequent oil removal etc is rarely worth while. Likewise care should be taken not to cause rupture of the skin. Animal Welfare experts familiar with this problem recommend that the sample consist of contaminated feathers, hair or fur, clipped off with strong clean unlubricated clippers or scissors or shaved off with a razor without breaking the skin or disturbing the feather or hair roots. Such a sample can be stored in a glass jar. If necessary, uncontaminated feathers, hair or fur may also be sampled separately for identification of the creature's own oils and fats in the sample. However, birds and other wildlife are protected under the Wildlife and Countryside Act 1981 and corresponding Scottish and Northern Ireland legislation. The Nature Conservancy Council (a) in Britain and the Wildlife Branch of the Department of the Environment in Northern Ireland should be informed if oiled birds or animals are encountered. Expert advice and assistance on the handling of live birds and animals can be obtained from the Royal Society for the Prevention of Cruelty to Animals (b) in England and Wales, the Scottish Societies for the Prevention of Cruelty to Animals (c) and the Ulster Society for the Prevention of Cruelty to Animals (c). Qualified veterinarians and the Royal Society for the Protection of Birds may also be able to help.

1.3 Sampling Ground Waters

Oil spilled on the ground may travel rapidly through unfilled fissures or pores to the water table. The degree of penetration depends on the viscosity of water solubility of the oil, the size of fissures in the strata, the size of the pores and type of material in the strata, and any additional water coming from the surface, for example rain. Oil products may be absorbed on soil and the material of the unsaturated zone, that is the layer between the soil and the water table, and may be subsequently washed off.

Much detailed work has been carried out in this field and some of the papers are listed in references 19 to 26.

When the oil reaches the water table it may form a "pancake" as portrayed in figure 9,⁽²⁷⁾. For this reason and the reasons given above the spread of oil at the water table can be very much larger than the area over which the original spillage occurred. In addition when the oil reaches the water table some of it may dissolve and be transported by natural groundwater flow. The quantity will depend on the composition of the oil, and whilst quantitatively the amount may be small the consequences may be serious because of the taste and odour which can be produced in the water either directly, or indirectly, for example after chlorination. As the oil remains in the soil or unsaturated zone both chemical and biological action can alter the rate of removal into the water phase. The way in which this occurs is not fully understood and it is more complex than for the case of oil on water surfaces discussed in section 1.1. above.

In an ideal survey of an oil spillage on the ground a sufficient number of bore holes would be drilled to completely surround the spillage area and so minimize the risk of not detecting the migration of oil in the ground water, but because of the cost, only a few

(a) Nature Conservancy Council, Water and Energy Policy Branch, 20 Belgrave Square, London SW1X 8PY (01-235 3241 or 4150).

(b) See entries under Royal Society for the Prevention of Cruelty to Animals in the local telephone directory or under Animal Welfare in the Yellow Pages.

(c) See entries under Animals in either the local telephone directory or the Yellow Pages.

observation boreholes are sunk. Samples are obtained from these boreholes by pumping at a low rate. Often it is advisable to sink some of these observation boreholes at various distances away from the spillage area along the path in which the water is expected to flow. Advice on this can be obtained from a hydrogeologist. In many cases the direction of groundwater flow can be assumed to be in the direction of nearby rivers or streams and often in the direction of the slope of the ground. However, in some places and at times of low water content a river may drain into the water table, and flows in unexpected directions are not unknown.

One method of sampling for dissolved oil in ground water is by taking pumped samples usually using a submersible pump. This will ensure that a sample of water representative of that in the aquifer is taken, although it will be an 'average' sample containing groundwater from the full thickness of the aquifer. Water should be pumped to waste before taking the sample and the pump and associated sampling lines should be cleaned between taking samples from the same borehole and between taking samples from different boreholes.

Manual samples can be obtained from the upper part of the water column using a 'bucket' type of sampler, (Fig 10a). Surface samples are important where there is a "pancake" of oil on top of the groundwater. They will probably not be representative of the water column as a whole. Another approach to the problem of representative sampling is to take samples from various levels in the borehole. A depth sampler, (Fig 10b) can be lowered to the required depth, and the air pressure removed from the collector to retain a water sample from that depth. Contamination of the sampler by floating oil when the sampler is lowered through the water column is a serious source of error when interpreting the results of analyses.

All of these methods of sampling are appropriate at sites where the aquifer is thin, homogenous and isotropic and where rapid vertical changes in groundwater composition do not occur. Mixing usually occurs in the water column, however, and samples cannot be considered as anything other than averaged samples of local groundwater; results can, therefore, be easily misinterpreted.

The problem of mixing in open boreholes can be overcome by use of the borehole packer method of sampling, (Fig. 10c). By this method depth-specific samples of groundwater may be taken by isolating specific sections of the borehole. Water is drawn from the selected interval of the formation by means of a small submersible pump positioned between the inflatable packer seals. This method is applicable only in unlined boreholes, it is time-consuming and often difficult to achieve a seal.

An alternative method of sampling from specific levels in the aquifer is to use in-situ depth samples. (Fig 10d)⁽²⁸⁾. In-situ sampling devices can be installed within a borehole and sealed in place to prevent vertical flow and to maintain the natural groundwater quality stratification within the aquifer. In this method, the sample intake and reservoir, which are permanently sealed in the borehole are connected to the surface by thin tubes. Samples may be removed by suction from shallow depths and by ejection using compressed gas from deep installations.

As has been emphasized in section 1.1, the materials of construction used in any sampling device must not contaminate the sample or tend to absorb hydrocarbons. It is preferable that samplers are constructed of materials such as glass, teflon or stainless steel which may be solvent rinsed without release of contaminants. The apparatus should be solvent rinsed before the sample is taken and then afterwards. This second wash should be included as part of the sample to be analysed.

When the ground water has been contaminated it should be sampled for at least a year after failing to measure an oil content such that any rise in the water table giving rise to a further release of oil during the hydrological cycle can be detected.

Where there may be highly volatile hydrocarbons any operations of drilling or sampling must be carried out in a safe manner. All machinery must be fitted with flame traps and spark arresters, and there should be no arcing to the atmosphere from any switchgear. Hydrocarbon detectors and alarms should be used, and the need for having adequate fire fighting equipment available should be surveyed. Further discussion of groundwater sampling is given in references 19-26.

1.4 Sampling of Soil and Rock

Usually the reason for sampling soil for analysis of its oil, fat or wax content is to establish the extent of a spill, or a succession of spills. The possible changes in the character of the spilled material and its migration into the lower layers of the strata have been discussed in section 1.3 above. Often the extent of the spillage can be established by visual examination and this can be confirmed within a few days by damage caused to the vegetation.

For sampling the soil and the upper layers of the strata a hand auger can be used, or a trench can be dug when samples can be taken at various levels. Ideally a survey of the soil should be carried out by taking enough “core” samples to completely surround the spillage area, but because of cost usually only one or two such samples are taken. Often hydrocarbons measured are partly or wholly of natural origin and it is strongly recommended that a comparison is made with samples from the same location which are uncontaminated with oil, fat or wax,⁽²⁹⁾.

When the unsaturated zone in the soil extends to depths greater than 2 metres the choice of drilling techniques used to recover material from the unsaturated zone depends mainly on the nature of the material to be drilled and by the requirements of the sampling programme. The most important consideration is that the methods employed should not introduce extraneous fluids into the samples. Normal water, mud or air-flush techniques are not generally satisfactory, though air-flush may have to be used where other techniques cannot.

Continuous flight augering is satisfactory for exploratory investigations when drilling through superficial deposits, chalk or soft sandstone. In the auger method, drilled material is carried upwards and sampled at the surface. The precise depth from which the bulk samples were obtained cannot be determined. More accurate sampling may be carried out by withdrawing the augers at selected depth intervals and recovering materials from the auger flight, or by using hollow stem augers.

For more detailed investigations, the drilling techniques are restricted to cable-tool percussion and air-flush rotary methods. Cable-tool methods are generally used in superficial deposits and chalk, whereas air-flush rotary methods are employed in sandstone and hard rock formations. Clearly volatile materials will be lost where air-flush methods are used. Both methods allow the recovery of relatively undisturbed samples, (for example, driven U100 samples and rotary cores). Further information on drilling techniques can be found in references 21 and 30.

In all drilling there is a serious risk of contamination by greases used on the tools and pipes etc and from fuel, derv etc. Careful precautions are essential and silicone greases should be specified for equipment that goes into the hole. Similar precaution should be taken with the lubrication of borehole casing joints.

All solid samples should be double sealed in polythene, with the removal of as much air as possible before sealing to reduce the loss of moisture or volatile compounds. It is possible that the outer 10–20mm of core obtained by drilling can be contaminated by groundwater or by wrapping material⁽³¹⁾. Where this is likely to be important, the outer 20–30 mm of solid core are discarded before the sample is analysed. Solid samples should be analysed as soon as possible after collection. Where storage is unavoidable samples should be kept at –18°C.

When drilling boreholes be sure to comply with the requirements of the Water Resources Act 1963, the Water Acts 1945 and 1974 and the Control of Pollution Act 1974 and corresponding legislation for Scotland and Northern Ireland; especially with respect to notification of the Institute of Geological Sciences and the Water Authority. Also consult the Water Authority as to whether they require the hole to be filled, sealed, or left open afterwards.

1.5 Sampling of Sewage

The normal recommended procedure for the sampling and preservation of sewage, sewage effluents and sewage sludges should be observed.

However, there are one or two exceptions such as the sampling of sewage “mousses” and “scums” containing oils, fats or grease from sewers or sewage treatment plants. These should be taken using similar techniques to those described for beach pollution, (see section 1.2). However, great attention should be paid to hygiene as these types of samples

may be reservoirs of pathogenic organisms. The samples should be analysed as quickly as possible as they can putrify rapidly, which can change the nature of the sample, particularly with respect to fats.

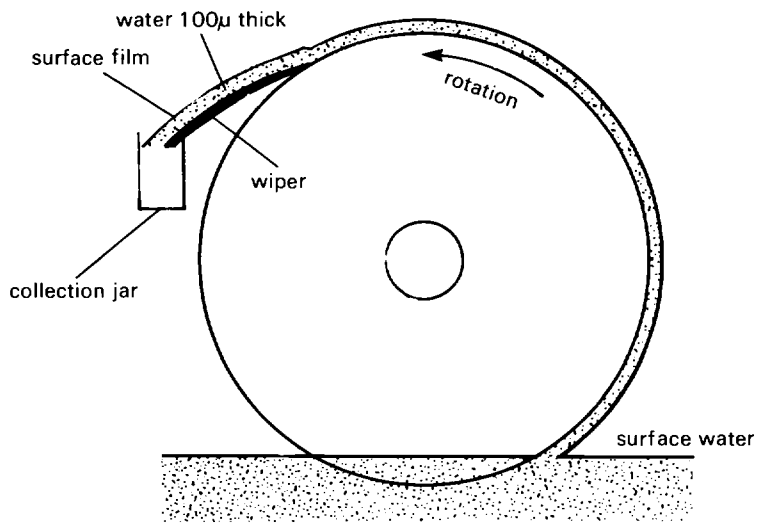
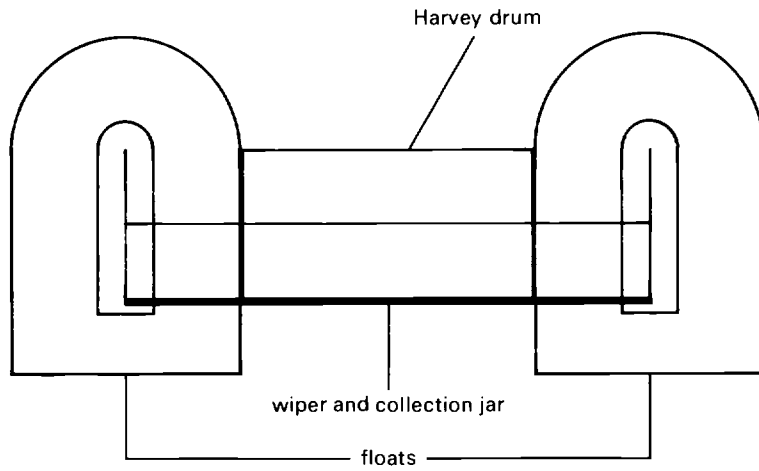
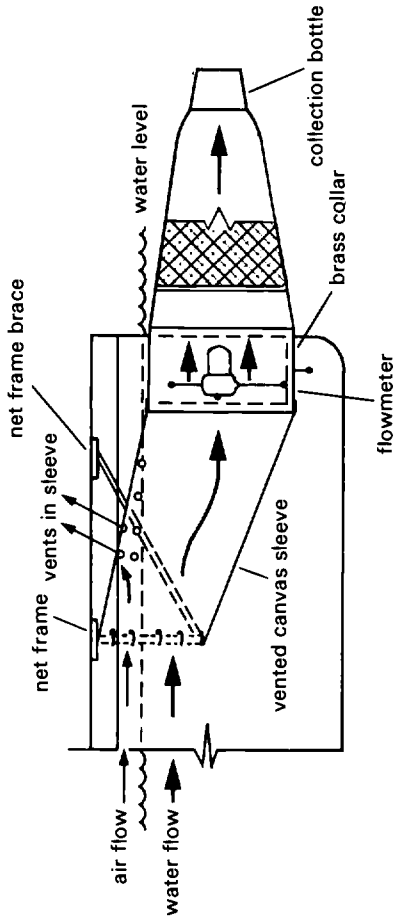
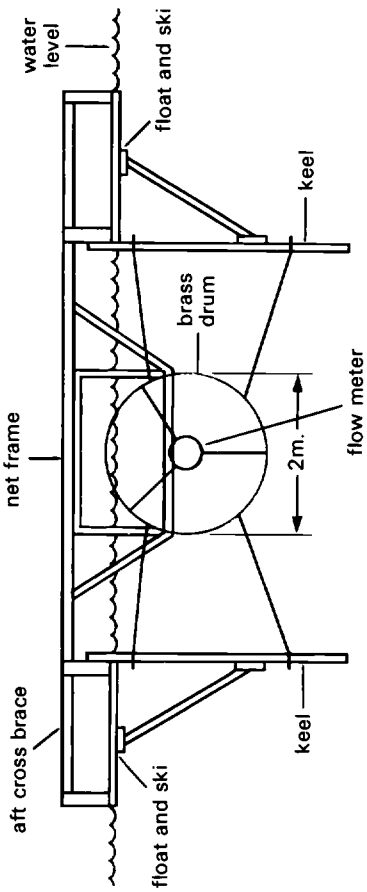

FIGURE 3 DIAGRAMMATIC REPRESENTATION OF THE HARVEY DRUM SAMPLER



SIDE VIEW SHOWING THE WAY THE NET IS ATTACHED



SECTION VIEW FROM THE FRONT

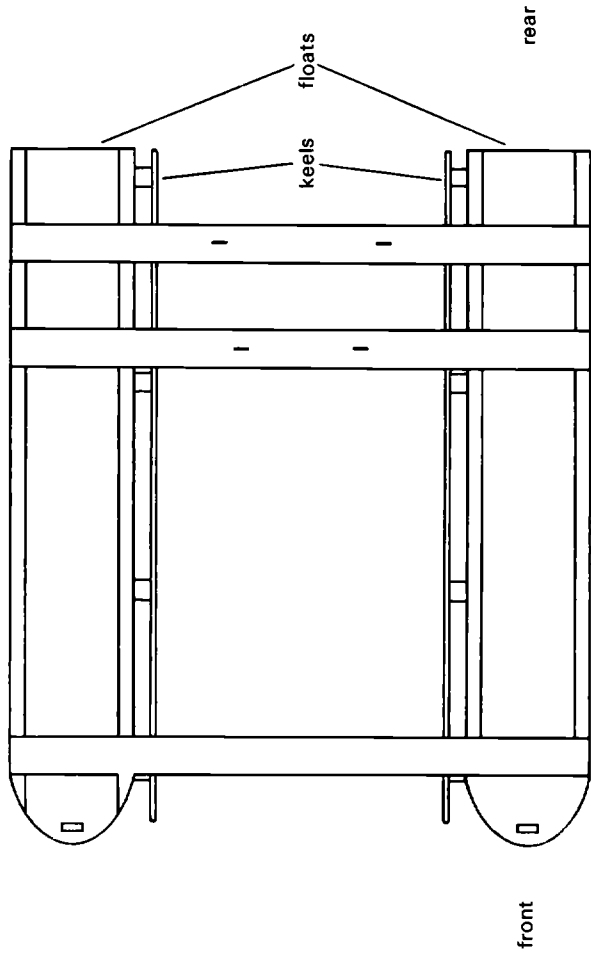

PLAN

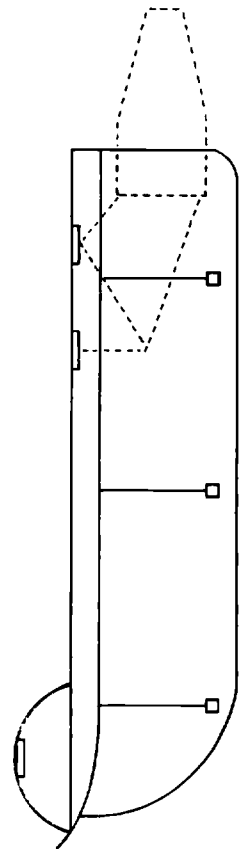

SIDE

FIGURE 4 THE NEUSTON NET SYSTEM (Refs 10,12)

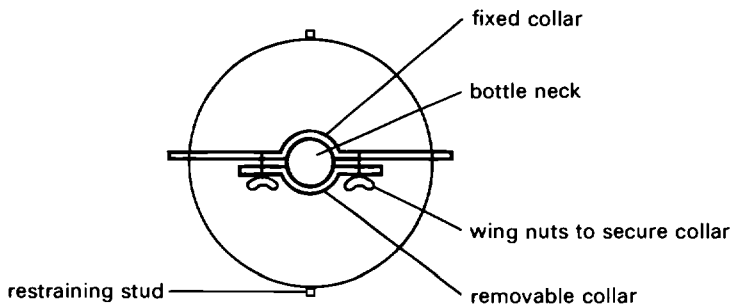
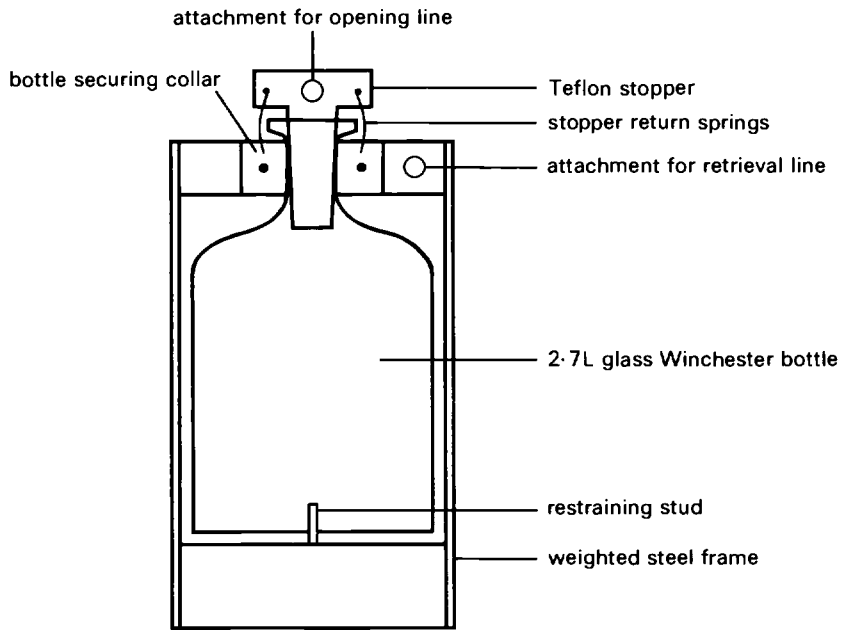

The sampling depth is set by a buoy fixed to the retrieval line

FIGURE 5 SHALLOW WATER SAMPLE, AS USED BY THE MINISTRY OF AGRICULTURE AND FISHERIES, BURNHAM-ON-CROUCH

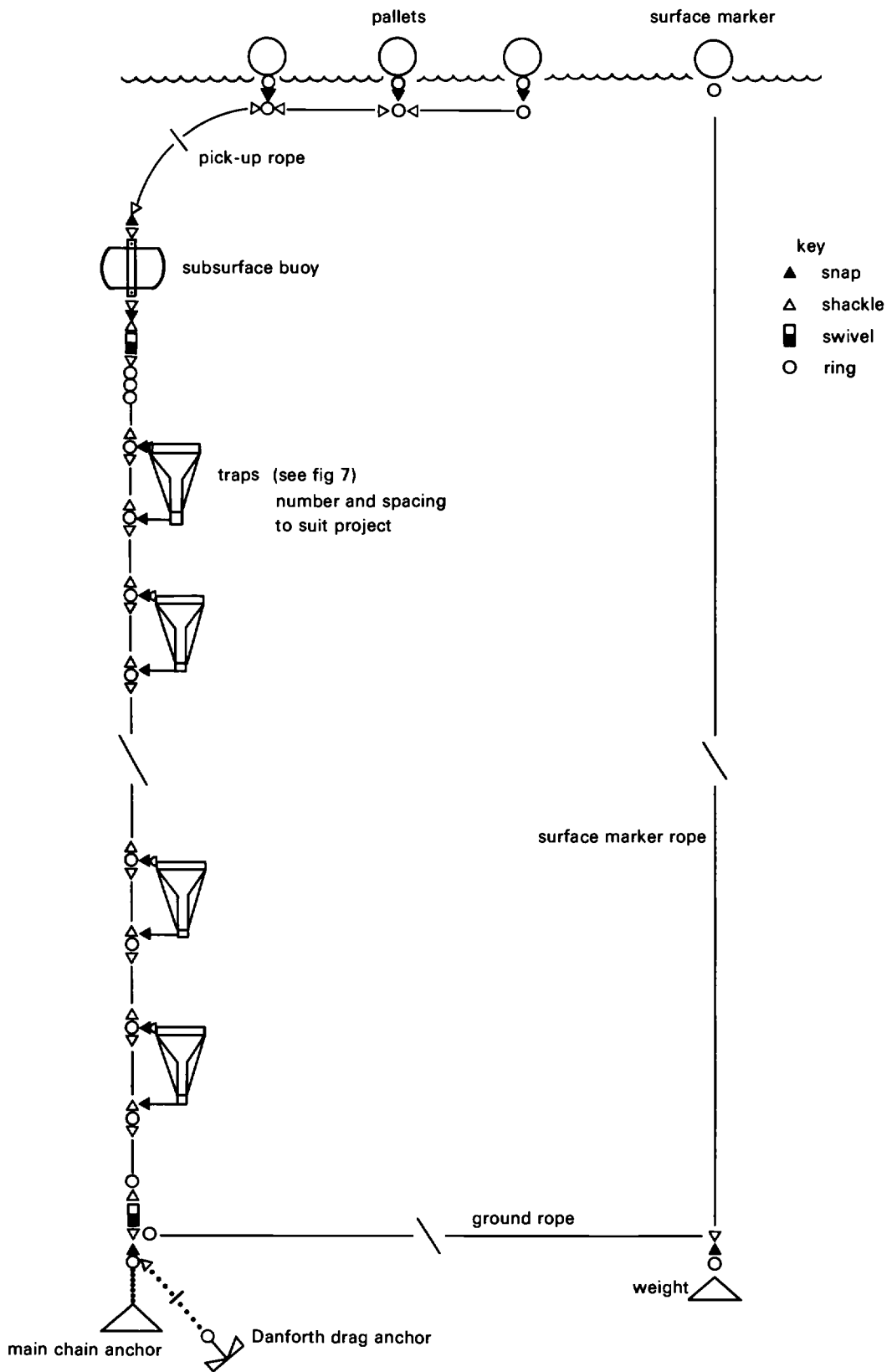

FIGURE 6 THE SEDIMENTATION RIG

(Reproduced by kind permission of Department of Agriculture and Fisheries Scotland DAFS)

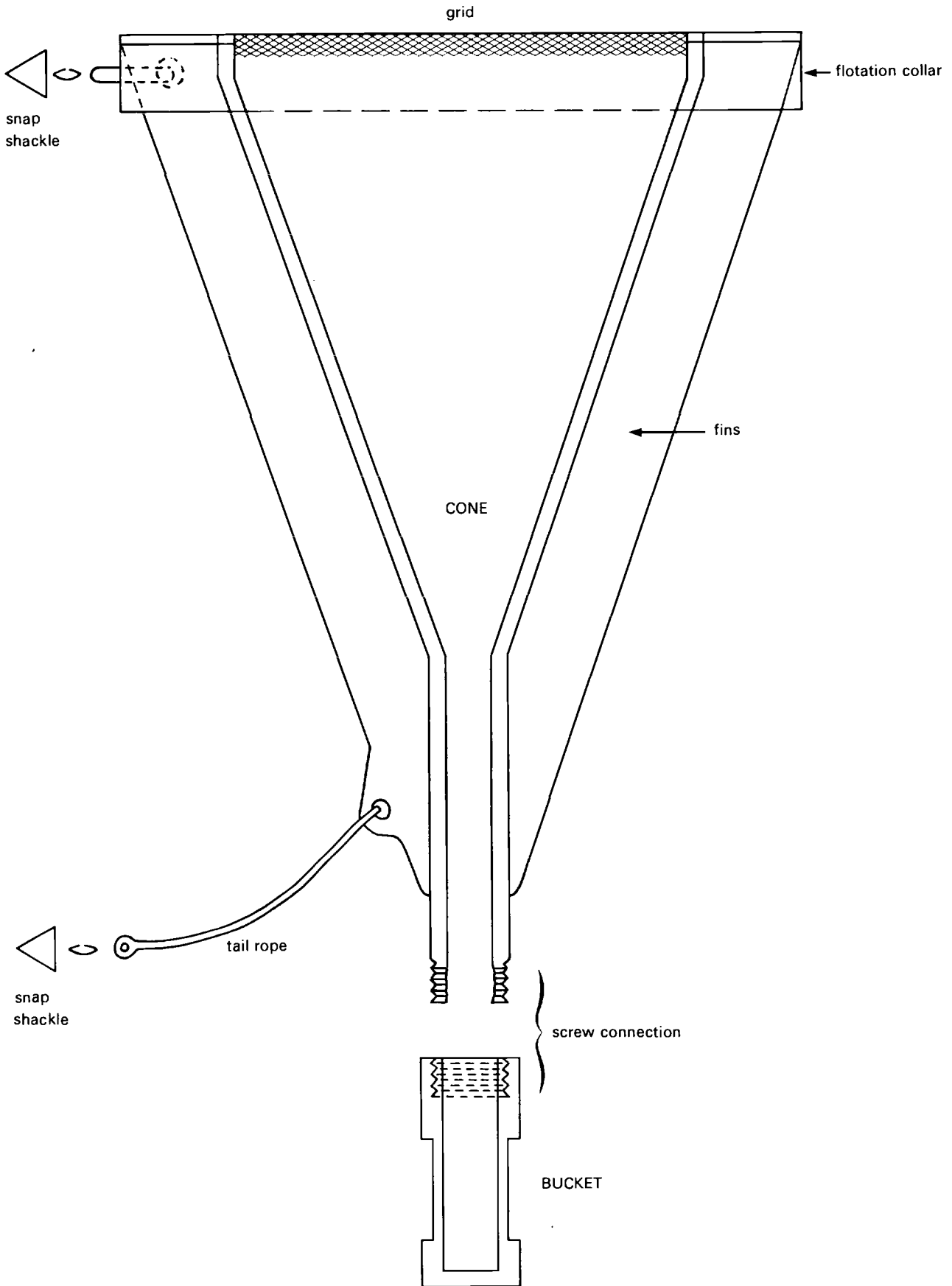
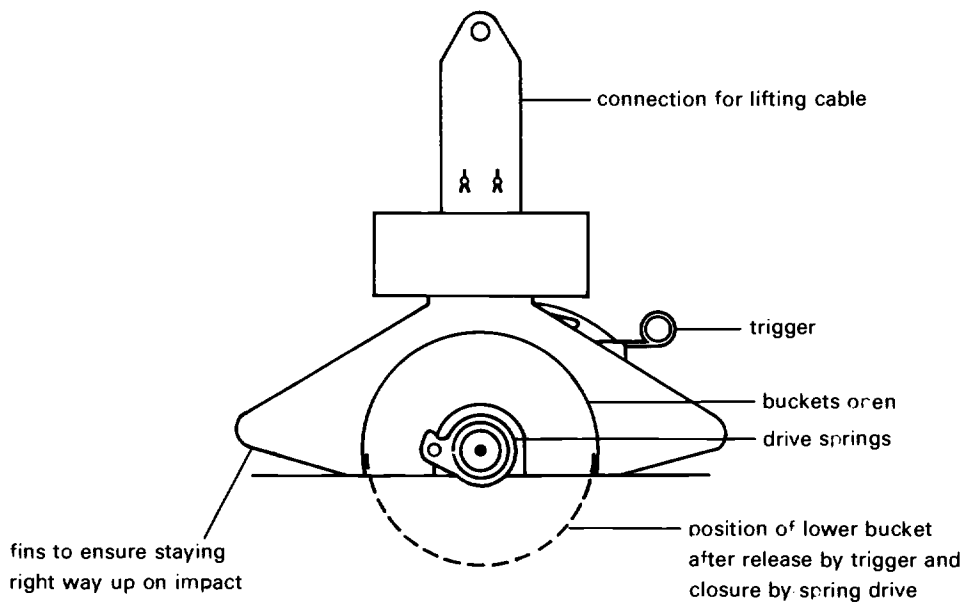

FIGURE 7 THE ABERDEEN SEDIMENTATION TRAP



Reproduced by kind permission of MAFF

FIGURE 8 SHIPEK SEDIMENT SAMPLER

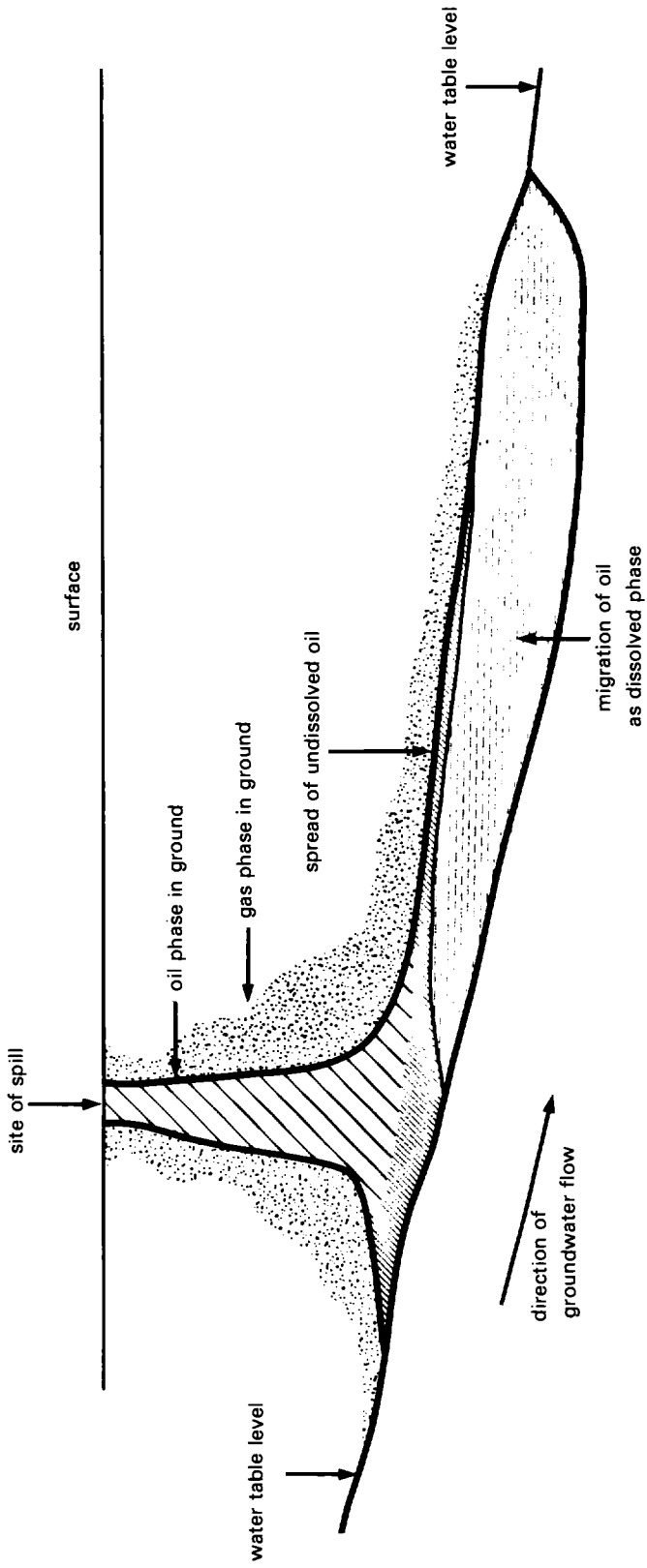
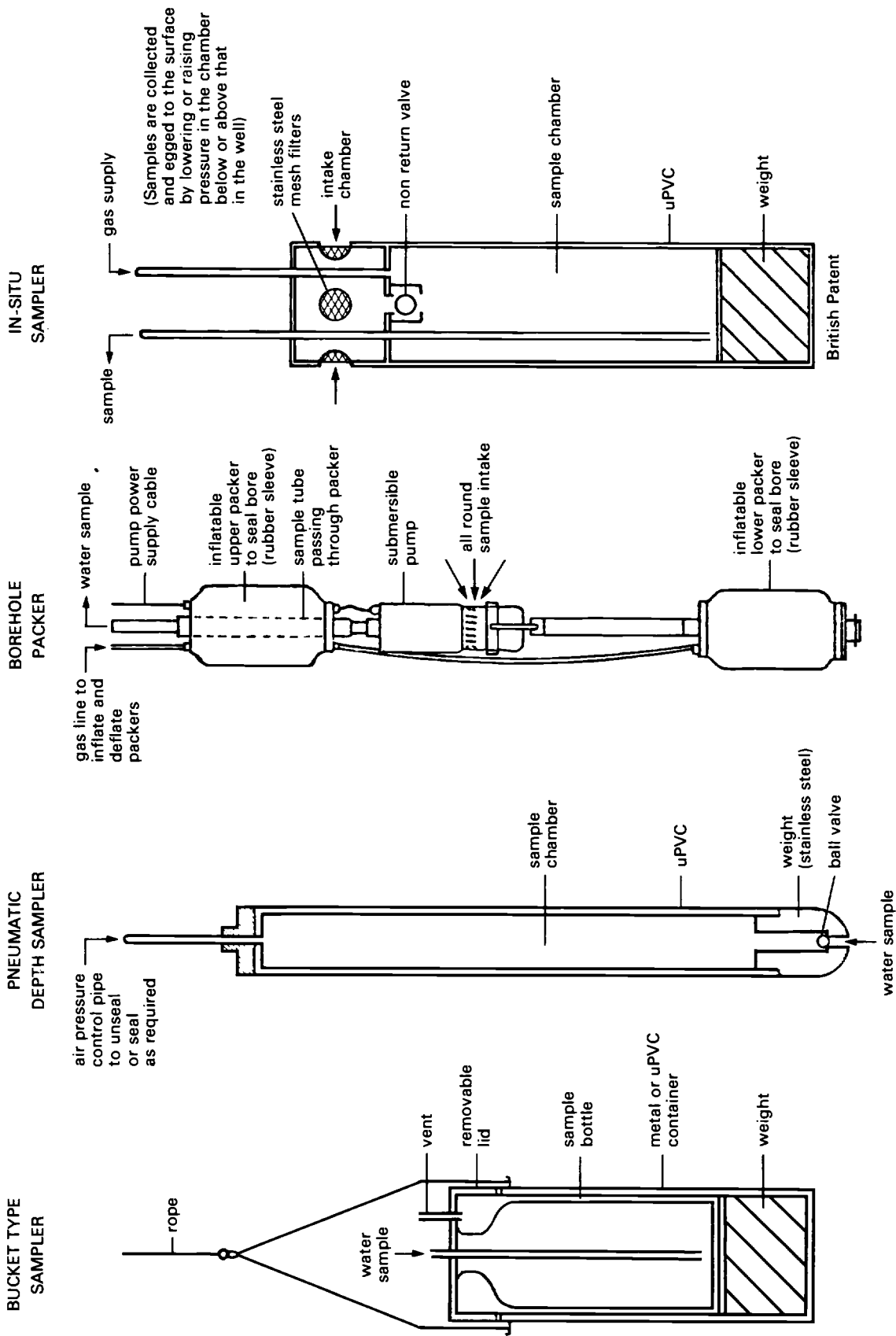

FIGURE 9 MOVEMENT OF OIL IN A POROUS SUBSOIL IN CONTACT WITH GROUNDWATER (ref 20)



(a)

(b)

(c)

(d)

FIGURE 10 GROUNDWATER SAMPLING TECHNIQUES (30)

2. Sampling of Oils, Fats, Waxes and Tars in Plant and Factory

The sampling and analysis of oils, fats, waxes and tars in a plant or factory effluent is of paramount importance since it is the last step in the control of the treatment process before discharge into the environment. Results of analysis of routine samples not only provide data on effluent quality, which enable a plant to ensure that it is producing an effluent within permitted quality levels, but they also provide an indication of any disturbance in inplant activities.

As the degree of turbulence in plant and factory systems is usually very much greater than in the natural environment which has been considered in part, 1, section 2.1 considers the nature of the sample and the sample environment. The time and frequency of sampling is referred to in section 2.2. The sample point location provides the topic in section 2.3 and section 2.4 considers the method of sampling.

Whilst the measurement of flow will not be considered here it is an important aspect of sampling and should not be neglected,⁽³²⁾.

2.1 Nature of the Sample and the Sample Environment

Assuming that gas, or highly volatile compounds that may change phase in the sampling procedure are not present in the effluent, waste water streams can be divided into four main types depending on the phases present.

- (a) single liquid phase
- (b) single liquid and solid phase
- (c) two immiscible or partially miscible liquids
- (d) two immiscible or partially miscible liquids and solid

(a) Single Liquid Phase

Provided that the sample is taken from a position which is in a fully turbulent condition there is little problem in obtaining a representative sample provided the sampling rate is sufficient to cater for the rate of change of concentration in the system.

(b) Single Liquid and Solid Phase

Where two discrete phases are present, and the solid has a greater density than the liquid a representative sample cannot necessarily be obtained even in fully turbulent systems because some settling of solid can occur to give a higher solids content at the bottom rather than at the top of a pipe where the solid has a greater density than the liquid. An example of this for the flow of sand and water along the horizontal pipe is shown in figure 11 where iso-concentration gradients are drawn,^(33,34). When the solid phase is substantially lighter than the liquid phase, an inversely similar segregation will occur with the solid phase at the top of the pipe, though the phase ratio may differ. Whilst sampling of the solid phase can give problems the dissolved materials can be representatively sampled provided conditions outlined in (a) are present.

(c) Two Immiscible or Partially Miscible Liquids

The type of flow in the system is determined by physical properties of the two liquids, their relative quantities and the flowrate. Five distinct patterns of flow can usually be obtained, namely:—

(i) Layer, (ii) bubble, (iii) plug, (iv) annular and (v) mist. Only in a mist flow condition where the particle size is below 20 microns can representative samples be obtained unless a mixing zone specially designed for each is incorporated into the flow system,^(21,30).

(d) Two Immiscible or Partially Miscible Liquids and a Solid

This is a further complication of case (c) above; the distribution of the solid can be affected by the nature of the flow regime, the interface between the two liquids, the relative densities, and the size and surface characteristics of the solid.

As outlined above the type of stream from which the sample is taken will determine whether it is representative. From these points it is evident that for most two phase situations, it is necessary to provide a zone with a high degree of mixing if a representative sample is to be obtained and to take from this zone discrete or snap samples. The representative nature of the sample obtained in the zone should be checked by analysing four to six samples taken simultaneously from different positions in the zone and comparing the results, (see reference 35). In many systems a degree of agitation is available at pumps or weirs. In situations where it is not possible to provide sufficient agitation and two phases are present, the distribution across the profile of the pipe or channel has to be measured. This can only be successful if the rate of change of concentration of species present is slow compared with the time taken to sample the distribution.

2.2 Time and Frequency of Sampling

Information is usually required over a period of time during which the effluent quantity may vary to such an extent that samples must be taken at a frequency which will adequately represent the quality and its variation. This choice can be contrasted with that of a sampling frequency based on subjective considerations or on the amount of effort available for sampling and analysis. This subject is discussed in detail in "General Principles of Sampling and Accuracy of Results", Part 4.5,⁽¹⁾.

It is sometimes useful to establish a cycle for a particularly determinand from an investigation of the pattern of plant operations. This must include the change in concentration resulting from flow through tanks, ponds etc., where dilution due to back mixing and dispersion may take place. Materials may be discharged at intermittent frequencies necessitating sampling at frequent intervals. Variations in the concentrations of a particular determinand may result from geographical and climatic conditions. Thus, for example, in the sea the proximity to a river mouth may cause fluctuations in concentration whilst periods of rain may decrease the concentration.

2.3 Sample Point Location

The sampling position in a pipe, or channel which forms the topic of discussion in this section, should be located where the greatest degree of turbulence occurs. As has been outlined in section 2.1 there is a greater chance of the sample being representative under these conditions. Since effluent conduits are often designed to cope with plant effluent and storm water flow, during dry weather conditions, and flowrate may be very low and a laminar flow condition may result. In the absence of a suitable turbulent situation the turbulent condition may be induced by restricting the flow, for example, by the use of a weir.

2.4 Methods of Sampling

Sample collection can be classified into five basic modes, namely:—

(a) **Discrete Samples (Individual and Sequential).** An individual discrete sample, sometimes called a grab sample, is one that is collected at a selected time and retained separately for analysis. A sequential discrete sample is a series of such samples which are usually taken at constant time intervals, but occasionally for constant increments of discharge when they are controlled by flow integrators.

(b) **Simple Composite Samples.** A simple composite sample, which is sometimes called a time composite sample, is one that is made up of a series of aliquots of constant volume V_c , collected at regular time intervals, T_c and combined into a single sample. Such a sample could be denoted by $T_c V_c$ meaning that both the time interval between successive aliquots and the volume of each aliquot are constant.

(c) **Flow Proportional Composite Samples.** A flow proportional composite sample is one collected in relation to the flow volume during the period of compositing, indicating the 'average' condition during the sampling period. One of the two ways of accomplishing this is to collect aliquots of equal volume, V_c but at variable time intervals, T_v , which are

proportional to the volume of the flow. That is, the time interval between aliquots is reduced as the volume of flow increases. Alternatively flow proportioning can be carried out by increasing the volume of each aliquot in proportion to the flow-rate, V_v , but keeping the time interval between aliquots constant, T_c .

(d) **Sequential Composite Samples.** A sequential composite sample is composed of a series of short-period composites, each of which is held in an individual container. For example, each of several samples collected during a one hour period may be composited for the hour. The 24-hour sequential composite is made up from the individual one hour composites.

(e) **Continuous Composite Samples.** A continuous composite sample is one collected by extracting a small continuously flowing stream from the bulk source and directing it into the sample container. The sample flowrate may be constant, Q_c , in which case the sample is analogous to the simple composite, or it may be varied in proportion to the total source flowrate Q_v , in which case the sample is analogous to the flow proportional composite.

A summary of these different types of sampling is given in Table 1. When oils, fats or waxes are present there is a difficulty in carrying out some of these procedures and at the same time obtaining a representative sample. For most circumstances when sampling aqueous streams containing oils, fats, or waxes sequential discrete sampling provides the most representative samples. If the number of samples is large, manual compositing can be carried out accordingly to preference, based on flow records or some suitable weighting scheme. However, errors will occur because of the problems in getting a representative sample from a two phase mixture, and because of the contamination of the surfaces of the equipment which is being used. The simple composite sample is often the best but will only be representative of the waste flow during the sampling period if the flowrate is relatively constant.

2.5 Sample Loops

A fast flowing stream may be taken from a main stream to a sampler, or analyser where a portion is withdrawn at a controlled rate and the excess is returned to the main stream. This side stream concept is known as a sampler loop. The combination of a sample loop and an automatic analyser provides a method of measuring rapid concentration changes of a determinand, thus allowing the main stream to be monitored and, where necessary corrective action to be taken. A sample loop can be used to sample from pipelines, weirs, sewers and discharges to rivers. The system is particularly useful where several analysers monitor one stream and where one analyser has to be switched from one to another stream and can be served by several sample loops. As a sample loop is usually designed to meet the requirements of a specific system it is useful to consider the key areas of design.

(i) **Sample Intake.** The object is to obtain a representative sample of the stream under examination without the sample point being choked. Ideally, where a continuous sample is to be taken from a pipeline the sample should be obtained with a probe facing into the stream where there is a high degree of turbulence and the sample can be taken at the isokinetic rate. In many sampling situations the degree of turbulence is a function of flowrate and the flowrate should be greater than 0.6 m.s^{-1} . Where this is not possible a bottom take off point is to be preferred, but it should be recognized that the sample will not be truly representative. To prevent blocking of the sample line the point should be protected by a coarse screen having a mesh size of 0.3 to 1 cm. This screen should be accessible and cleaned frequently. Where there is an open channel or weir at the sampling site, a pumped flow has to be obtained for the loop.

(ii) **Design of Sample Loops.** To minimize the tendency of effluents to cause corrosion and deposition in the loop it should be constructed of stainless steel (or other non corrodable non absorbent material in the event that the sample corrodes stainless steel) and have a bore between 7 and 25 mm. There should be a minimum of bends in the loop and they should not be acute. Preferably valves in the system should be of the straight through type, and should not be lubricated. The flowrate in the pipeline should be greater than 0.6 m.s^{-1} and preferably 1.25 m.s^{-1} . The length of the line should be as short as possible and preferably not greater than 7 m.

Whilst the measurement of flow will not be considered here it is an important aspect of sampling and should not be neglected⁽³²⁾. The flow in the sample loop must be kept as fast as possible to ensure that the time lag is low. The greater the range between the maximum and minimum flowrate of the main stream the more difficult it is to select a satisfactory

flow in the sample loop and to obtain a sample which has been taken at the isokinetic flowrate.

So that manual checks can be made, a sample point for 'grab' samples should be provided on all sample loops. This sample point should be located just prior to the point of discharge of the loop. In some loop systems constant head chambers are sometimes used, but it should be recognized that they will seldom give a representative sample from a multi-phase system. Indeed, the acquisition of a representative sample by and from a sample loop is difficult and may not be possible under all conditions particularly where there are large changes in the quantity and type of phases present in the main stream. Where there is doubt about the representative nature of a sample, this aspect should be checked. The flowrate in the loop should be checked at least once a week as there is often the possibility of gradual restriction in the flow. These problems can sometimes be minimized by including a simple air or fresh water purge which can be used in counter-flow on a routine basis. When serious fouling occurs it may be necessary to mechanically remove deposits after dismantling the system. Often this means replacing blocked sections. Where sections are not completely choked it is sometimes possible to use chemical cleaning agents. For example, oils, fats and waxes can sometimes be removed using caustic soda, detergents, or organic solvents.

Some typical designs of sample loop systems are shown in figures 12 and 13. Several features on each of these designs are for specific requirements. Thus in figure 12 the design caters for a flammability hazard in that the installation is contained in an air pressurized building, and in figure 13 the stream being sampled is assumed to be hot and so a cooler is included.

2.6 Automatic Sampling Techniques

Automatic sampling techniques are essential for samples collected by flow proportional composite, sequential composite and continuous composite methods as outlined in section 2.4. Many different designs of sampler have been described and a number are made or marketed in many countries. General details have been described in "General Principles of Sampling and Accuracy of Results", Part 4.8.2⁽¹⁾. The choice of the type of sampler is made difficult by the variety of transport systems so that multiphase samples in the collecting receiver may often be non-representative of the stream being sample. The sample can be transported by three methods, namely:—

(a) **Mechanical Method.** In this a cup, either by rotation, or attached to a chain is used to collect a 'grab' sample. The rate of collection can be geared to the flow-rate, and so can be flow proportional. The maximum lift is about 60 m.

(b) **Forced-flow Method.** A pump is used to convey the sample continuously to a receiver. This is usually a centrifugal pump for samples which might contain oils, fats or waxes, as other types which have a discontinuous operation, cannot pump sufficiently quickly, or cannot provide a sufficient head. Often a submersible pump is used but the difficulty of removing it from the system for maintenance sometimes gives problems. Where there is the possibility of flammable conditions occurring, the selection of the drive motor for the pump must be carefully examined. Compressed gases can be used to avoid electrically driven motors, but the quantity of gas is often too great to make this a reasonable proposition.

(c) **Suction-Lift Method.** In this class a vacuum is used to suck the sample into a container. The vacuum may be partial and applied by a pump or from a previously evacuated receiver. There is a head limitation of 9 m and volatile components can be lost. It is difficult to design a vacuum system in which the sample flow-rate can be varied in proportion to the stream flow-rate.

Many different designs of samplers have been described, but in a highly competitive and rapidly changing field it is not possible to give an up-to-date survey. The references given in the section 4.8.2 of "General Principles of Sampling and Accuracy of Results 1980",⁽¹⁾ are included here⁽³⁶⁻⁴²⁾. The suitability of an automatic sampler in a particular application should be critically assessed. A check list is given below:—

- (i) Method of sampling
- (ii) Frequency of sampling required
- (iii) Type of analysis to be done
- (iv) Flow measurement required
- (v) Design of sample intake
- (vi) Control of the system
- (vii) Reliability required

Size of solid particles
in microns

% distribution based on
concentration at mid point
of pipe (shown by a dot)
taken as 100

15 or
below

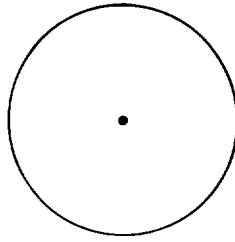

60

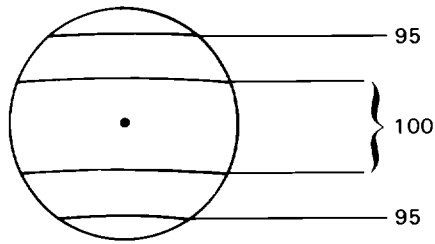

150

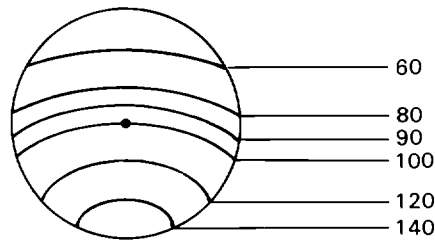

450

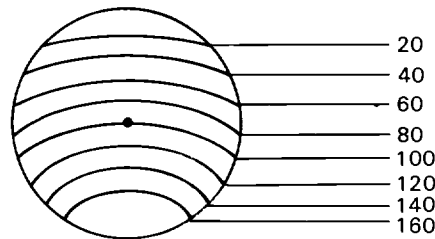



FIGURE 11 TYPICAL ISOCONCENTRATION GRADIENTS FOR SAND SUSPENDED IN WATER
(see ref 34)

non return valve 
 ordinary valve 

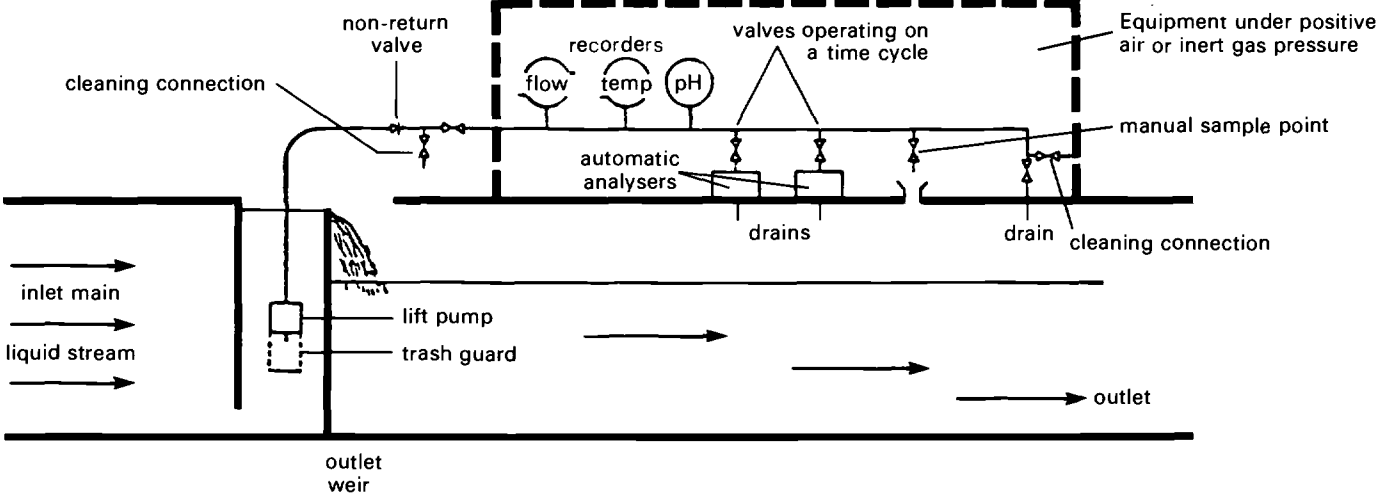

FIGURE 12 TYPICAL OPEN LOOP SAMPLE INSTALLATION (after ref 34)

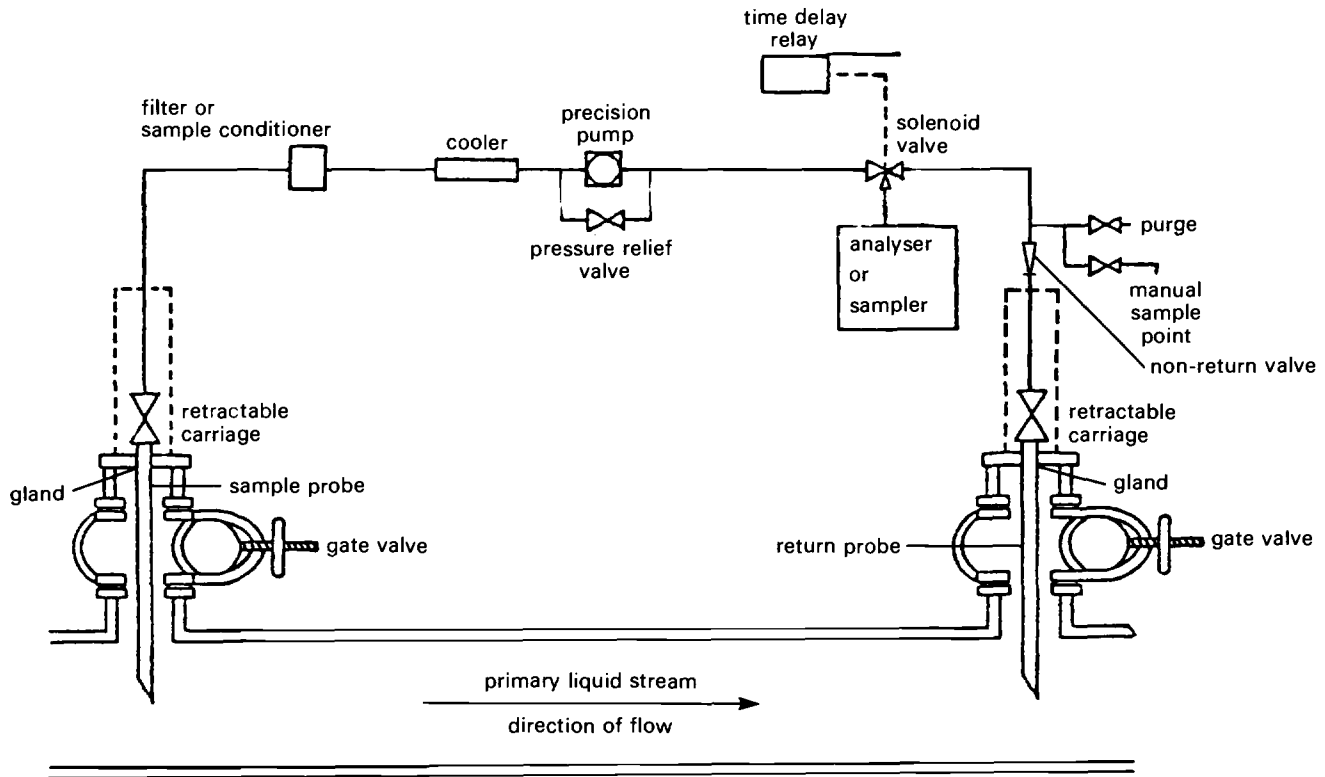

FIGURE 13 TYPICAL CLOSED LOOP SAMPLE INSTALLATION (ref 34)
 (not to scale)

3. Sample Handling

Careful attention to the details of sample handling are essential if accurate results are to be obtained, and the outline of the general requirements have been described in “General Principles of Sampling and Accuracy of Results 1980” sections 4.7 to 4.11,⁽¹⁾. This includes under the term sample handling, sample volume required, specification of the sample containers, specification of the preservation required, sub-sampling, and the recording of data. It must be emphasized that, when sampling oils, fats, and waxes some material may be deposited on the walls of the container and in consequence the practice of washing out the container with sample as a first stage should not be followed, and subdivision of the sample must not be carried out unless the procedure used accounts for the material adhering to the sample container. It is usually possible to re-use containers several times provided they are cleaned between each use. Because of this, it is preferable to use glass bottles as the condition of their walls is more easily inspected. It is essential to record all the details of the sample. A suitable check list is as follows⁽³⁴⁾:

- Sample Number
- Date of Sampling
- Time of Sampling*
- Source of Sample and or location from where sample obtained
- Sample Volume
- Preservation used
- Mode of sampling (if filtered give details)*
- Parameters (Determinands) to be analysed
- Measurements taken at time of sampling
 - for example: temperature
 - rate of flow
 - depth
 - on the spot analyses and tests

Other comments including if necessary, purpose of sampling. Information on anomalies or unusual conditions or occurrence (for example a thin grey stripe ran across the surface of the deposit was sampled separately — sample No —) must be given.

Name (printed) and also signature of sampler

* If the sample was taken over a period of time or is a composite, details should be given and whether mixed or not prior to bottling.

4. References

1. Standing Committee of Analysts, *General Principles of Sampling and Accuracy of Results, 1980*. Her Majesty's Stationery Office, London.
2. Gordon, D C., and Keizer P D., Estimation of Petroleum Hydrocarbons in Seawater by Fluorescence Spectroscopy: Improved Sampling and Analytical Methods, *Fisheries and Marine Service, Technical Report, No 481*, 28, 1974.
3. Gordon D C, Keizer P D., and Dale J, Estimates Using Fluorescence Spectroscopy of the Present State of Petroleum Hydrocarbon Contamination in the Water Column of the North-Western Atlantic Ocean, *Mar. Chem* **2**, 251–261, 1974.
4. Kordyban E and Cuker S., Instrumentation to Measure the Oil Thickness on a Wavy Water Surface, *Rev. Sci. Instrum.*, **49**(11) 1574–1578, 1978.
5. Wangersky P J and Zika R C., *The Analysis of Organic Compounds in Sea Water*, National Research Council of Canada, Publication No NRCC 16566, 1977.
6. Mikhaylov V I and Oradivskiy S C., Study of Methods of Sampling Seawater from the Ocean's Surface Microlayer and Results of Determination of Oil in Various Regions of the Atlantic Ocean, *1st American-Soviet Symposium on Chemical Pollution of the Environment*, 92–101, 1977.
7. Harvey G W, Microlayer Collection from the Sea Surface: A New Method and Initial Results, *Limnol. Oceanog.*, **11**, 608–613, 1966.
8. Daumas R A., Laborde P L, Marty J C and Saliot A, Influence of Sampling Method on the Chemical Composition of Water Surface Film, *Limnol, Oceanog.*, **21**, 319–326, 1976.
9. Timoshchuk V N., Description of the “Afrodita-1” Device for Collecting the Neustic Water Layer. Radioecological Studies of the Mediterranean Sea, *Naukova Dumka*, Kiev, 1970.
10. Hamilton E I, Clifton R J., Techniques for sampling the air-sea interface for estuarine and coastal waters. *Limnol, Oceanog* **24**. 188–193, 1979.
11. David P M. The Neuston net. A device for sampling the surface fauna of the ocean *J. Mar. Biol. Assoc.* **45**, 313–320, 1965.
12. Wellman A M and Wellman W J. Mini-Neuston Sampler Suitable for Collection of Floating Oil at Sea, *Laboratory Practice*, 31–33, 1975.
13. Morris B F, Petroleum: Tar Quantities Floating in the North-Western Atlantic Taken with a New Quantitative Neuston Net, *Science*, **173**, 430–432, 1971.
14. Levy E M, Intercomparison of Niskin and Blumer Samplers for the Study of Dissolved and Dispersed Petroleum Residues in Seawater. *J. Fish, Res. Bd. Can.*, **36** 1513–1516, 1979.
15. Zsolnay A, Caution in the Use of Niskin Bottles for Hydrocarbon Samples, *Mar. Pollut. Bull.*, **9** 23–24, 1978.
16. Clark R C, Blumer M, and Raymond S O, A larger Water Sampler Rupture-disc Triggered for Studies of Dissolved Organic Compounds, *Deep-Sea Res*: **14** 125–128, 1967.
17. Gardner W D, Sediment Trap Dynamics and Calibration: a Laboratory Evaluation, *J. Mar. Res.*, **38** 17–39, 1980.
18. Gardner W D, Field Assessment of Sediment Traps, *J. Mar. Res.*, **38** 41–52, 1980.
19. Hunter-Blair A., Oil Spills in Chalk Aquifers, *A paper presented at the Water Research Centre, Institute of Hydrology Sixth Colloquium*, Water Research Centre, Medmenham Laboratory, 17–12–1980.

20. Hunter-Blair A., Groundwater Pollution by Oil Products, *J.I.W.E.S.*, **34**(6) 557–570, 1980.
21. Concawe, *Protection of Groundwater from Pollution*, Report No., 3/79, Concawe 1979.
22. Dietz D, N Pollution of Permeable Strata by Oil Components, *Proc Seminar at Aviemore*, Institute of Petroleum, London, 127–239, 1970.
23. Somers J A., The Fate of Spilled Oil in the Soil, *Hydrog. Sci*, **XIX** 4(12) 507–521, 1974.
24. Birk F and Vorreyer C., The Behaviour of Oil in Fissured Rocks — Demonstrated by Typical Oil Incidents, *Proc International Symposium on Groundwater Pollution by Hydrocarbons*, Prague, 1978.
25. Ineson J and Packham R F, Contamination of Water by Petroleum Products, *J Brit Waterworks Ass.*, **XL**, **31**, 307–326.
26. *Proc International Symposium of Groundwater Pollution by Oil Hydrocarbons*, Prague 1978.
27. Concawe, *Strack Model to Establish Optimum Location for a Drain to Collect Oil Polluted Groundwater: An Experimental and Numerical Evaluation*, Report No 13/77, Concawe 1977.
28. British Patent 1527751
29. Concawe, *Methods for the Analysis of Oil in Water and Soil*, Report No 1/68 3, Concawe, 1968.
30. Naylor J A et al, The Investigation of Landfill Sites, *Technical Report TR 91* Water Research Centre, 1978.
31. Barber C. Morris P J and Knox K, Groundwater Sampling: the Extraction of Institial Water from Cores, Rocks and Sediment by High Speed Centrifuge, *Technical Report TR54*, Water Research Centre, 1977
32. Concawe, *Sampling of Liquid Refinery Effluents*, Report No 3/75, Concawe, 1975.
33. Shelly P E., *Sampling of Waters and Wastewater*, US Environmental Protection Agency, PE EPA-600/4-77-039. (NTSI PB-272 664), 1977.
34. Concawe, *Sampling of Liquid Effluents from Refineries*, Report No 7/80, Concawe 1980.
35. Wilson A L and Hilder D W, Statistical Tests Required in Checking the Homogeneity of Impurities in Cross-sections of River, *Technical Memorandum TM72*, Water Research Centre 1972.
36. Little A H, *Water Pollution Control (London)*, 1973, **72**, 606–617.
37. Wood L B and Stanbridge H H, *Water Pollution Control (London)*, 1968, **67**, 495–520.
38. United State Environmental Protection Agency *Handbook for Monitoring Industrial Wastewaters*, United State Government Printing Office, Washington, 1973.
39. Nancy K H and Weber W J., in *Treatise on Analytical Chemistry, Part III, Vol 2*, (eds Kolthoff I M, Elving P J and Stross F H), Wiley-Interscience, London, 1971, pp 413–462.
40. Bouveng H O, *Pure App Chem.*, 1969, **19**, 267–290
41. Tarazi D F, Hiser, L L, Childers R E., and Boldt C A, *J. Water Pollution Control Fed.*, 1970 **42**, 708–732.
42. Cottrell D R, Kitchen D and Whitby F J, Imperial Chemical Industries, *Brixham Laboratory Report No BL/A/1582*, Imperial Chemical Industries, Brixham.

Table 1 Summary of Sample Type

| Sample Type | Designation | Principle | Comments | Disadvantages |
|-----------------------------|-------------------------------|---|--|--|
| Discrete (Individual) | D | Sample quantity is taken over a short period of time, generally less than 5 minutes. | Most commonly used. Provides a "snapshot". | Tells nothing about time variations or average conditions. |
| Discrete (Sequential) | D _s | Series of individual discrete samples taken at constant increments of either time or flow-rate. | Used by some automatic samplers: impracticable to collect manually if time interval is less than 1 in 15 minutes. Provides a history of variation with time. | Most useful if rapid fluctuations are encountered or detailed characterization is required. Many analyses required with attendant higher cost. |
| Simple Composite | T _c V _c | Constant aliquot volume; and constant time interval between aliquots. | Most widely used type of composite at the present time. | Only useful if variations in flow are relatively small, say ±15%. |
| Flow Proportional Composite | T _v V _c | Constant aliquot volume; time interval inversely proportional to flow | Most common type of flow proportional composite. | Requires a flowmeter and a flow record if composited manually. |
| Flow Proportional Composite | T _c V _v | Constant time interval; aliquot volume proportional to instantaneous flow-rate. | Used in some automatic samplers. | Requires a flowmeter and a flow record if composited manually. |
| Flow Proportional Composite | T _c V _v | Constant time interval; aliquot volume proportional to flow since last aliquot was taken. | Used by few automatic samplers; easily done manually. | Requires a flowmeter a flow record if composited manually. |
| Sequential Composite | S | Series of short-term composites (often simple) but held separately for analysis. | Used by some automatic samplers: requires fewer samples than sequential discrete. | Most useful if rapid fluctuations are encountered and some time history is desired. Higher analytical cost. |
| Continuous Composite | Q _c | Constant sample extraction rate. | Only useful for single phase flows eg drinking water; not widely used. | May require inordinately large sample volume; may not be representative if variations are large. |
| Continuous Composite | Q _v | Sample extraction rate is proportional to flow rate. | Seldom used. | Requires a flowmeter and complicated sampling equipment. |

Address for Correspondence:

The Secretary
The Standing Committee of Analysts
Department of the Environment
Romney House
43 Marsham Street
LONDON
SW1P 3PY

Standing Committee of Analysts

Members of the Committee Responsible for this Method

| | | | |
|--------------------|--|--------------------|-------------------------|
| Mr J F Armson | 2, 3 (June 1979 to January 1981) | Mr G J Holland | 1 |
| Mr B T Ashurst | 3 | Dr D T E Hunt | 1 (After May 1980) |
| Dr G I Barrow | 1 (After December 1976) | Mr R Law | 2 |
| Mr J Beckett | 3 (March 1978 to September 1979) | Mr W M Lewis | 1 (until January 1980) |
| Mr G A Best | 1 (After September 1980) | Mr P J Long | 1 |
| Mr J R Borland | 1 (to February 1978) | Mr G H Mansfield | 2 |
| Dr J M Carter | 1 | Dr P J Matthews | 3 |
| Mr P Chave | 1 (After May 1981) | Mr J C McCullins | 1 |
| Mr R V Cheeseman | 2 | Mr P Morries | 1 |
| Dr G W Clayfield | 1 | Mr D Myles | 1, 3 |
| Mr B E P Clement | 1 (After February 1978) | Mr A H Nield | 1 |
| Dr V Collins | 1 (to January 1977) | Dr D I Packham | 1 (After October 1980) |
| Dr R L Cooper | 1 (to January 1981) | Dr H A Painter | 1 (to June 1982) |
| Dr B T Croll | 1, 3 | Mr J F Palframan | 3 |
| Mr T A Dick | 1 | Dr S J Patterson | 1 (until July 1979) |
| Mr J W B Dutton | 1 (After September 1977) | Dr R Perry | 3 |
| Mr M Fielding | 3 | Mr L R Pittwell | 1 |
| Mr G Firth | 3 | Dr J E Portmann | 1, 3 |
| Dr J Gardiner | 1 (After July 1980) | Mr L D Purdie | 1 |
| Mr G I Goodfellow | 1 (After January 1980) | Mr B D Ravenscroft | 1 |
| Mr K Goodhead | 1 (from July 1978 to September 1980) | Mrs S M Rawson | 3 |
| Mr T R Graham | 1 (After January 1977) | Mr B Rhodes | 1 (after July 1978) |
| Dr D W Grant | 1 (After January 1981) | Mr M L Richardson | 3 |
| Dr I Hall | 3 (until May 1979) | Prof J P Riley | 1 |
| Mr I Harper | 1 (from July 1978 to May 1981) | Mr R Sinar | 1 (died April 1979) |
| Dr P R Hinchcliffe | 3 (until March 1978 and November 1979– March 1980) | Dr S Torrance | 3 |
| Mr E Hodges | 1 | Dr A M Ure | 1 (After August 1979) |
| | | Dr K C Wheatstone | 3 |
| | | Mr B T Whitham | 1 |
| | | Dr D A Williams | 2 |
| | | Mr A L Wilson | 1 (until December 1980) |
| | | Mr R Wood | 1 (to July 1978) |

1 Member of the Main Committee

2 Member of the Panel

3 Member of Working Group 6 (from January 1976 unless stated).

Specialist advice was also obtained from the Nature Conservancy Council, the RSPCA and RSPB, which help is gratefully acknowledged.

HER MAJESTY'S STATIONERY OFFICE

Government Bookshops

49 High Holborn, London WC1V 6HB

13a Castle Street, Edinburgh EH2 3AR

41 The Hayes, Cardiff CF1 1JW

Brazennose Street, Manchester M60 8AS

Southey House, Wine Street, Bristol BS1 2BQ

258 Broad Street, Birmingham B1 2HE

80 Chichester Street, Belfast BT1 4JY

*Government publications are also available
through booksellers*